



Assembly and Operating Instructions for Outback® Spectrum Flamer Charcoal Barbecues



Photographs are not to scale.
Specifications subject to change
without prior notice.



WARNING

- For outdoor use only - do not use indoors! Not for commercial use.
- Read instructions before using the appliance. Failure to follow instructions could result in death, serious bodily injury, and/or property loss.
- **WARNING!** Accessible parts may be very hot. Keep children and pets away!
- **CAUTION:** Do not use spirit or petrol for lighting or re-lighting! Use only firelighters complying to EN1860-3!
- **WARNING!** This barbecue becomes very hot. Do not move it during operation!
- Install this barbecue on a safe and even surface.
- Any modification of the appliance, misuse, or failure to follow the instructions may be dangerous and will invalidate your warranty. This does not affect your statutory rights.
- Retain these instructions for future reference.

A. Parts List

Quantities vary according to model purchased. Specifications subject to change without prior notice. For more details on hardware, please see 'Hardware Reference Diagram'.

	CODE	PART	QTY	Outback® Spectrum Flamer
BODY	A1	Grill Lifting Handle	2	✓
	A2	Cast Iron Grill	2	✓
	A3	Charcoal Basket Handle	2	✓+
	A4	Charcoal Basket	1	✓
	A5	Barbecue Body	1	✓
	A6	Front Panel	1	✓+
	A7	Ash Tray Handle	1	✓+
	A8	Ash Tray	1	✓
TROLLEY	B1	Side Shelf	2	✓
	B2	Front Left Leg	1	✓
	B3	Rear Left Leg	1	✓
	B4	Front Right Leg	1	✓
	B5	Rear Right Leg	1	✓
	B6	Leg Endcap	2	✓+
	B7	Wheel	2	✓
	B8	Hubcap	2	✓
	B9	Axle	1	✓
	B10	Trolley Base	1	✓
HARDWARE	C1	Trolley Bolt	24	✓
	C2	Body Support Bolt	8	✓
	C3	Spacer	8	✓
	C4	Wing Nut	8	✓
	C5	Washer	2	✓
	C6	Locknut	2	✓

✚ Pre-Assembled Component

B1. Spectrum Flamer Parts Diagram

Quantities vary according to model purchased. Specifications subject to change without prior notice. For more details on hardware, please see 'Hardware Reference Diagram.'

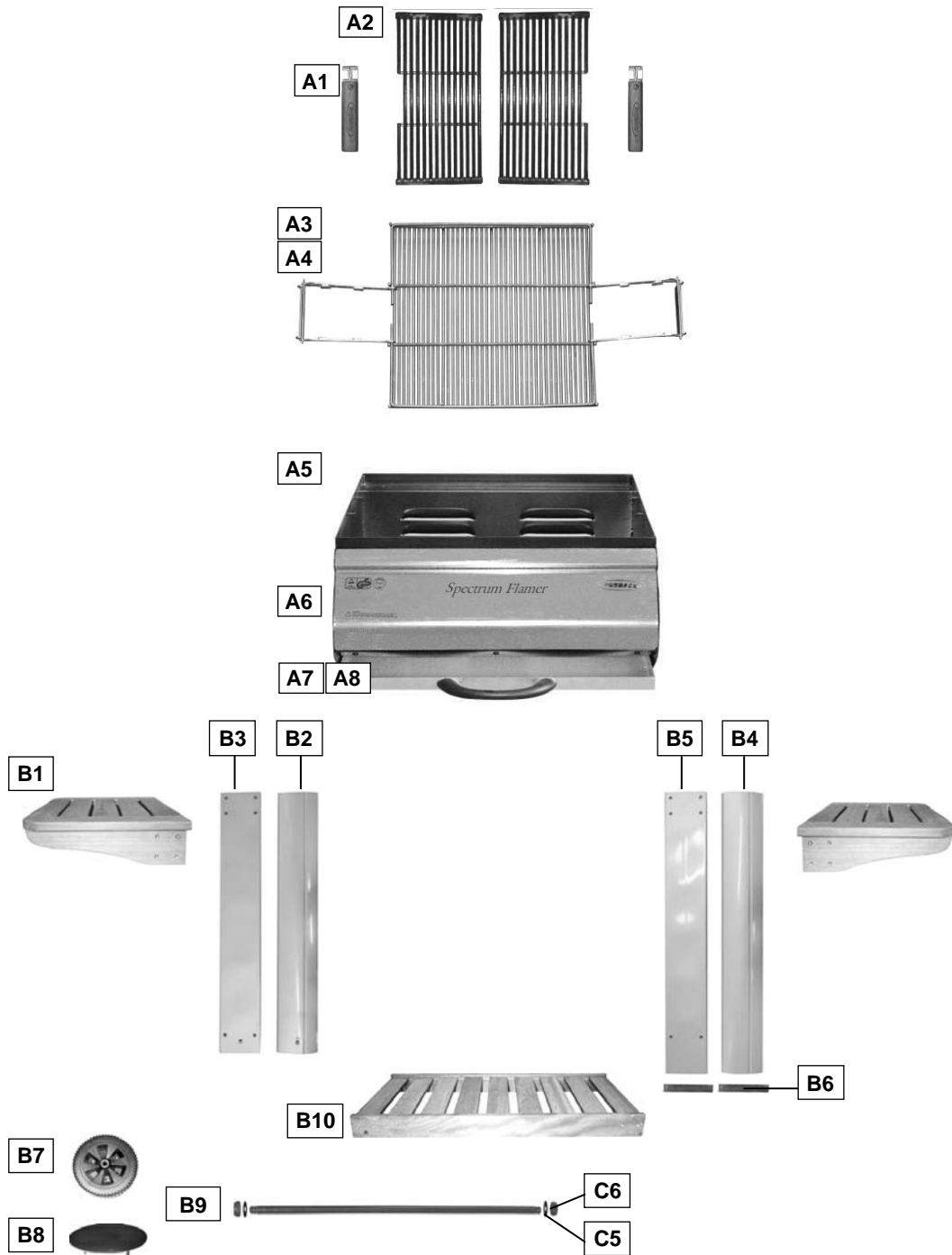

B2. Spectrum Flamer Hardware Reference Diagram

Specifications subject to change without prior notice.

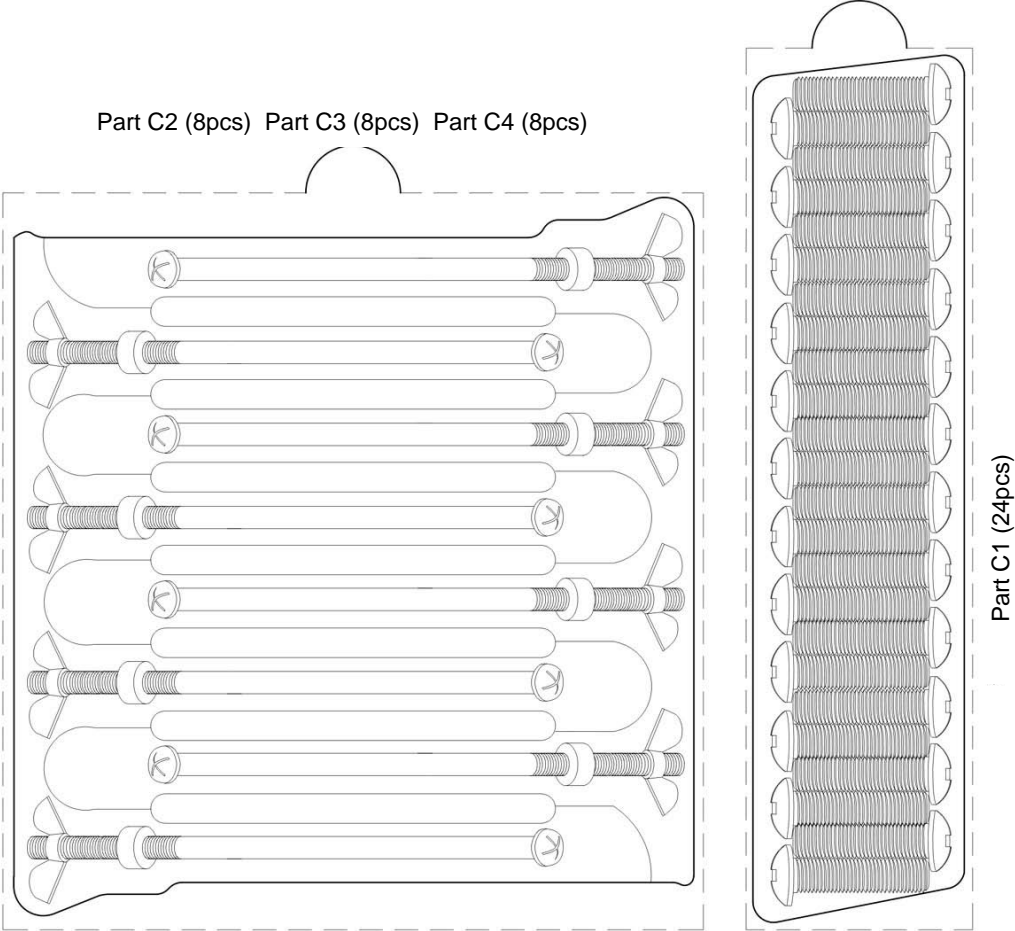

D. Assembly

TOOLS NEEDED FOR ASSEMBLY:

Medium size flat blade or Phillips/crosspoint screwdriver, adjustable spanner or metric spanner set

1

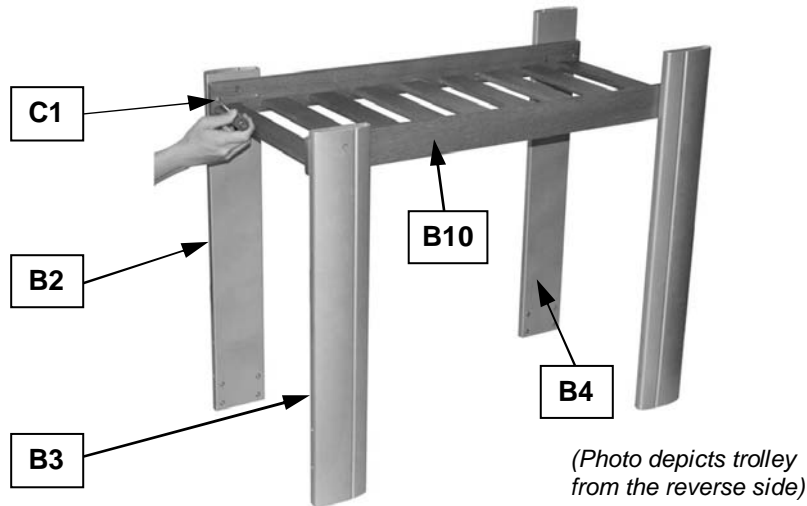

Attach the legs (B2, B3, B4, B5) as shown to the trolley base (B10) using the trolley bolts (C1).

2

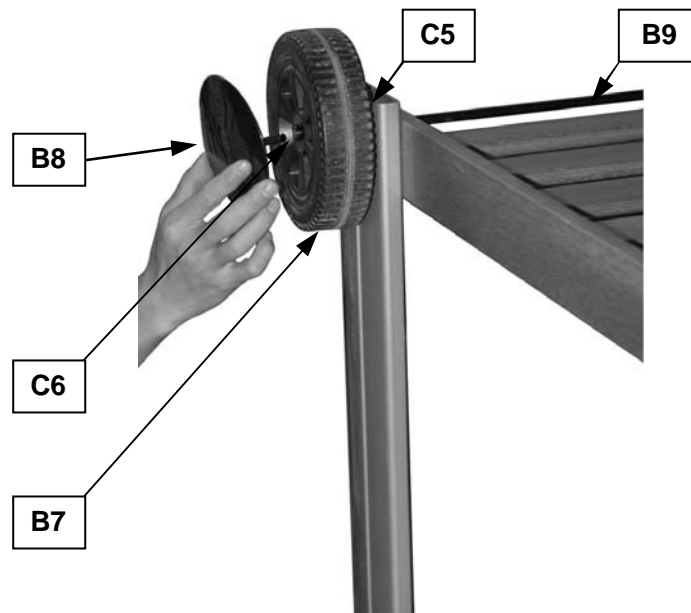

Slide the axle (B9) through the corresponding holes in the short legs. Place a washer (C5) on each end of the axle. Slide the wheels (B7) over each end of the axle. Secure the wheels into place with the locknuts (C6). Snap the hubcaps (B8) into the wheels.

3

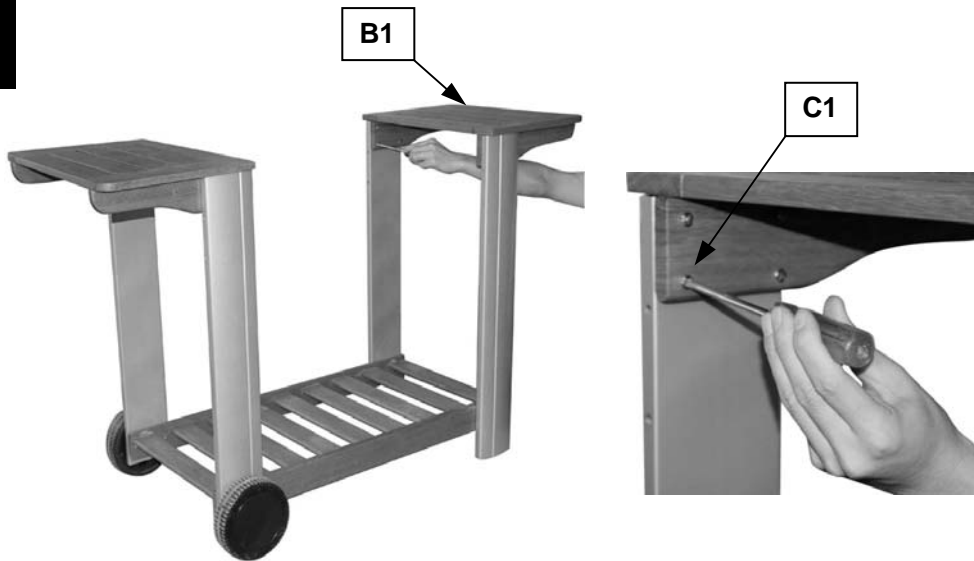

Attach the side shelves (B1) to the front/rear left legs (B2,B3) and front/rear right legs (B4,B5) using the trolley bolts (C1).

4

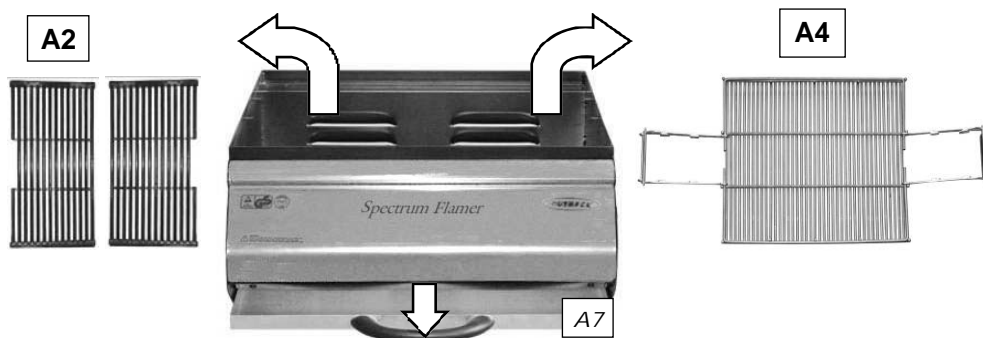

Remove all cast iron cooking components, charcoal basket, ash tray, and any internal packaging from the barbecue body.

5

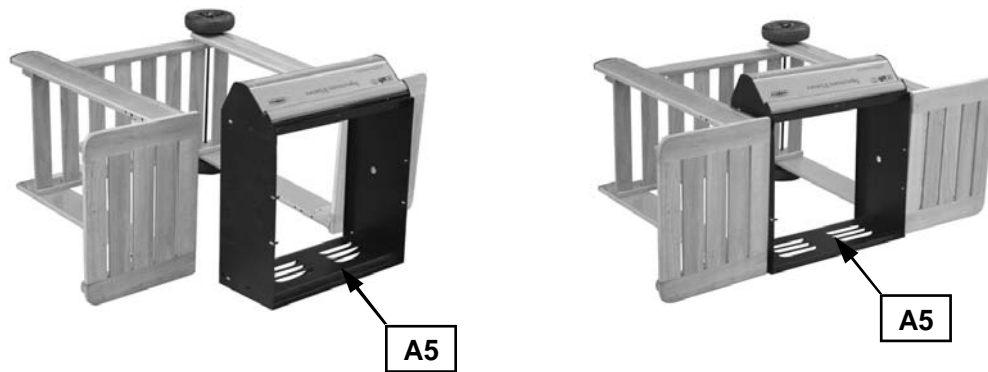

Lay the assembled trolley on its side. Lay the body (A5) on its back and slide into position between the trolley legs.

6

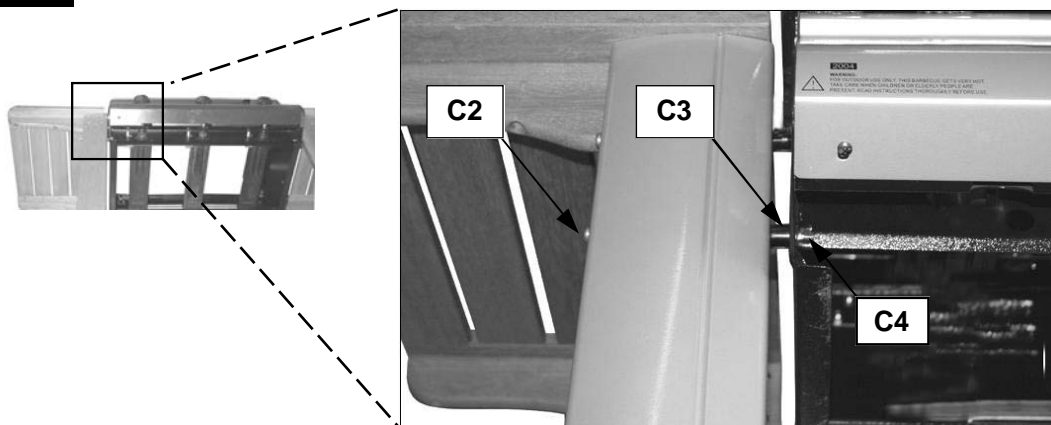

With the barbecue laid on the ground, insert a body support bolt (C2) through the short leg, through a spacer (C3), through the sidewall of the body, and secure the bolt with a wing nut (C4). Repeat the process for all the legs until the body is completely fixed to the trolley.

NOTE: When positioning the body of the barbecue, ensure the wheels at the left of control panel.

7

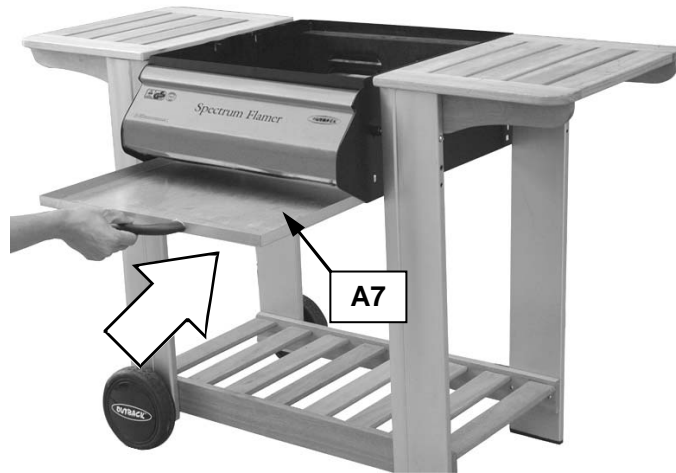

Replace the ash tray (A7) by sliding it underneath the barbecue body (A5).

8

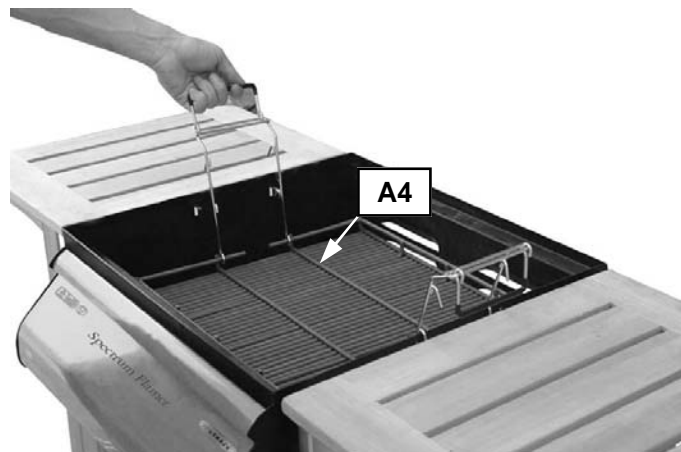

Lay charcoal basket (A4) into body making sure the basket rests on the lowest level of hooks on the adjustable handles.

9

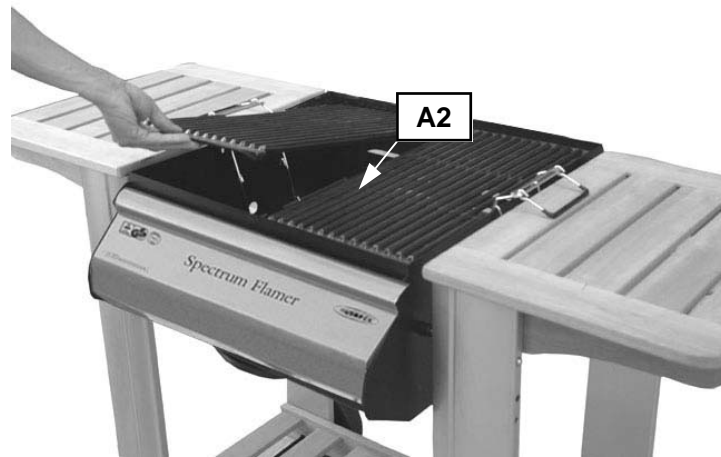

Lay cast iron grills (A2) into barbecue body (A5).

ASSEMBLY IS NOW COMPLETE.

**PROCEED TO THE NEXT PAGE FOR INSTRUCTIONS ON
OPERATION AND MAINTENANCE.**

E. Important Information

Please read and understand these instructions before assembly and use.

- Retain these instructions for future reference.
- For outdoor use only – do not use indoors!
- Do not move the barbecue while lit.
- Ensure the ash pan is in place before use.
- Never remove the ash pan whilst the barbecue is in use. Wait until the barbecue is completely cooled before removing it.
- Modification of the barbecue may be dangerous, is not permitted, and will nullify any warranty.
- Use this barbecue only on a stable, flat plane.
- Do not use within 1m of any flammable structure or under any combustible surface.
- Caution: Do not use spirit or petrol for lighting or re-lighting! Use only firelighters complying to EN1860-3.
- Do not store flammable materials near this barbecue.
- Do not use aerosols near this barbecue.
- WARNING! This barbecue becomes very hot. Do not move it during operation.
- WARNING! Keep children and pets away.
- Failure to follow the instructions in this manual could result in serious injury or property damage.
- If you have any queries regarding these instructions, contact your local dealer.

F. Installation

F1. Selecting a Location

This barbecue is for outdoor use only and should be placed in a well-ventilated area on a safe and even surface. Take care to ensure that it is not placed UNDER any combustible surface. The sides of the barbecue should NEVER be closer than 1 metre from any combustible surface. Keep this barbecue away from any flammable materials!

G. Operation

G1. Warning

- Before proceeding, make certain that you understand the **IMPORTANT INFORMATION** section of this manual.
- This barbecue is designed for charcoal use only. We do not recommend the use of lump wood charcoal or lump wood based charcoal products as they burn too quickly in this

design. We recommend using charcoal briquettes. Use only enough briquettes to cover the bottom of the charcoal basket in a single layer. Do not overload the charcoal basket. The maximum amount of briquettes to be used at any one time is 2.0kg.

G2. Lining the Ash Tray

Line the ash tray with aluminium foil. This will protect the tray, help better reflect heat, and make cleaning easier when barbecuing is finished.

G3. Starting the Charcoal

- Make sure the charcoal basket is in the highest position before lighting the charcoal.
- Caution: Do not use spirit or petrol for lighting or re-lighting! Use only firelighters complying to EN1860-3.
- When placing charcoal, never allow charcoal to be closer than 5cm to the surrounding sides of the barbecue body. The maximum amount of charcoal to be used at any one time is 2.0kg.
- Block Type Starters – Form charcoal in a pyramid around it. Light the starter block. When charcoal is well lit, spread around the charcoal grid and add more as necessary.
- Liquid Starters – Place charcoal in a shallow tin. Pour liquid charcoal starter onto charcoal and wait 5-10 minutes so that starter is allowed to penetrate into the charcoal. Then place charcoal on grid in a pyramid formation. Light charcoal. Allow time for charcoal to become well lit. Spread charcoal in a uniform layer, so that each lump is just touching. When the charcoal is ashed over (grey coating of ash over each lump) you are ready to begin cooking.
- Do not begin cooking until charcoal has an ashed-over coat.
- Do not attempt to cook whilst charcoal is flaming.

G4. Preparation Before Cooking

To prevent foods from sticking to the porcelain, please use a long handled brush to apply a light coat of cooking or vegetable oil before each barbecuing session.

It is recommended to operate the barbecue with red-hot charcoal for at least 30 minutes before first use. The barbecue and grills are now ready to be used for cooking.

G5. Using the Adjustable Charcoal Basket

Warning: Handles can become hot during use. Please wear oven gloves and take care when handling the adjustable charcoal basket.

Heat can be controlled by raising or lowering the charcoal basket using the adjustable handles. For normal cooking, set the charcoal basket to the lowest level. As charcoal becomes consumed, the basket can be raised to the highest level in order to compensate for heat loss. Also, the basket can be adjusted higher on one side and lower on the other to facilitate warming of foods on the lower side, and cooking on the higher side. The basket should NEVER rest directly on top of the ash tray. Always use either the lowest or highest levels of hooks on the adjustable handles. The charcoal basket must always be positioned in the middle of the barbecue body, between the two stop pins.

G6. Flare-Up Control

Flare-ups occur when meat is barbecued and its fat and juices fall upon the hot charcoal. Smoke helps give food its barbecued flavour, but avoid excessive flare-up to prevent food being burned. To control flare-ups, it is advisable to trim away excess fat from meat and poultry before grilling. Flare-ups can be extinguished by applying baking soda or a salt directly onto the charcoal. Always protect your hands when handling anything near the cooking surface of the barbecue.

If a fat fire should occur in the ash tray, wait for the fire to go out. Do not pull out the ash-collecting tray or douse charcoal or tray with water.

G7. Replenishing the Charcoal

To replenish the charcoal during use, remove the food from the grill. With protected hands, use the grill-lifting handles provided to lift the grill. Once the grill is lifted, add the charcoal, carefully replace the grill, and continue cooking when the charcoal is ready. When using the handles to move the grill, take care to position them correctly so that the grill is stable.

H. Care and Maintenance

Clean your barbecue after use, especially before extended periods of storage. Ensure the barbecue and its components are sufficiently cool before cleaning.

- Never douse the barbecue with water when its surfaces are hot.
- Never handle hot parts with unprotected hands.

In order to extend the life and maintain the condition of your barbecue, we strongly recommend that the unit be covered when left outside for any length of time, especially during the winter months. A full range of heavy-duty Outback® covers is available for all models. Do not leave the barbecue exposed to outside

weather conditions or stored in damp, moist areas.

Even when your barbecue is covered for its' protection it must be inspected on a regular basis as damp or condensation can form which may result in damage to the barbecue. It may be necessary to dry the barbecue and the inside of the cover.

H1. Porcelain Coated Cast Iron Cooking Surfaces

Clean with hot, soapy water. To remove any food residue, use a mild cream cleaner on a non-abrasive pad. Rinse well and dry thoroughly. We do not recommend cleaning grills and griddles in a dishwasher.

H2. Adjustable Charcoal Basket

When fully cooled, use the handles to shake the basket vigorously until all loose ash falls through into the ash tray. Dispose of any unburned charcoal and remove remaining residue with a brass wire brush.

H3. Ash Tray

After every use, check the tray for ash or fat build-up on the aluminium foil. Discard the ash and foil, and wash any remaining ash or fat from the tray. Failure to clean thoroughly may cause fat fires. These fires can severely damage your barbecue and are not covered by the warranty.

H4. Barbecue Body

Regularly remove excess grease or fat from the barbecue body with a soft plastic or wooden scraper. It is not necessary to remove all the grease from the body. If you need to clean fully, use hot soapy water and a cloth, or nylon-bristled brush only. Remove cast iron cooking grills before full cleaning.

H5. Trolley

Your trolley is manufactured using a hardwood suited to outdoor use, provided it is treated with Teak oil or similar after assembly and on a regular basis thereafter. Hardwood will naturally weather and change its appearance. It is quite natural for small cracks to appear on the surface of the wood.

H6. Fixings

All screws and bolts, etc. should be checked and tightened on a regular basis.

Specifications are subject to change without prior notice.

OUTBACK UK LTD LIMITED 10 YEAR WARRANTY

OUTBACK barbecues are warranted to the original purchaser against defects in materials and workmanship. Porcelain coated barbecue bodies, porcelain coated roasting hoods and stainless steel roasting hoods are warranted for a period of ten (10) years from the date of purchase. OUTBACK UK will, within this period, supply replacements for defective parts free of charge provided that:

- ◆ The product has not been used for trade, professional or hire purposes.
- ◆ The product has not been subjected to misuse or neglect, including fat fires and flare ups.
- ◆ The product has not sustained damage through foreign objects, substances or accidents.
- ◆ The care and maintenance instructions given in your Outback manual have been followed.

This warranty is offered as an extra benefit and is in addition to the customers' statutory rights.

If you have any queries regarding the assembly or use of your barbecue please contact Outback UK

In the unlikely event that you experience problems with this barbecue, please contact:

Customer Service
Outback UK
Unit 2 Farleigh Hill
Tovil
Maidstone
Kent ME15 6RG

Tel: 01622 671771

Fax: 01622 673101

e-mail: customerservice@outbackuk.com

website: www.outbackuk.com

Published October 2008