



**Assembly and Operating Instructions for Outback®
Excelsior 2 Burner, 3 Burner, 6 Burner Stainless Gas Barbecues With Side Burner**



Photographs are not to scale.
Specifications subject to change
without prior notice.



WARNING

- For outdoor use only.
- Read instructions before using the appliance. Failure to follow instructions could result in death, serious bodily injury, and/or property loss.
- Warning: accessible parts may be very hot. Keep young children away.
- Do not move the appliance during use.
- Turn off the gas supply at the gas bottle after use.
- Do not change the gas bottle when the appliance is hot.
- Any modification of the appliance, misuse, or failure to follow the instructions may be dangerous and will invalidate your warranty. This does not affect your statutory rights.
- Retain these instructions for future reference.
- Leak test your barbecue annually. Check the hose connections are tight and leak test each time you reconnect the gas bottle.

FOR YOUR SAFETY

If you smell gas:

1. Shut off gas to the appliance.
2. Extinguish any open flame.
3. Open barbecue lid or hood.
4. If odour continues, discontinue use and contact your local dealer.

FOR YOUR SAFETY

1. Do not store or use petrol or other flammable vapours or liquids in the vicinity of this or any other appliance.
2. A gas bottle not connected for use shall not be stored in the vicinity of this or any other appliance.

Parts List

Quantities vary according to model purchased. Specifications subject to change without prior notice. For more details on hardware, please see 'Hardware Reference Diagram'.

	CODE	PART	QTY	Outback® Excelsior 2 Burner	Outback® Excelsior 3 Burner	Outback® Excelsior 6 Burner
HOOD	A1	Hood Handle	1	✓+▲	✓+▲	✓+▲
	A2	Hood (<i>Pre-Assembled to Body</i>)	1	✓+▲	✓+▲	✓+▲
	A3	Hood Panel	1	✓+	✓+	✓+
	A4	Heat Indicator and Nuts	1	✓+	✓+	✓+
BODY	B1	Barbecue Body	1	✓▲	✓▲	✓▲
	B2	Burner	★	2	3	6
	B3	Control Panel	1	✓+▲	✓+▲	✓+▲
	B4	Knob	★	2	3	6
	B5	Drip Tray	1	✓▲	✓▲	✓▲
	B6	Drip Tray Left Bracket	1	✓	✓	✓
	B7	Drip Tray Right Bracket	1	✓	✓	✓
	B8	Drip Pan	1	✓	✓	✓
	B9	Foil Liner	1	✓	✓	✓
	B10	Flame Tamer	★	2	2	4
	B11	Grill	2	✓▲	✓▲	✓▲
	B12	Griddle	1		✓▲	✓▲
	B13	Hose and Regulator	1	✓	✓	✓
	B14	Warming Basket	1	✓+▲	✓+▲	✓+▲
TROLLEY	C1	Side Burner Shelf	1	✓	✓	✓
	C2	Side Shelf Shield	1	✓▲	✓▲	✓▲
	C3	Front Left Endcap	1	✓▲	✓▲	✓▲
	C4	Rear Left Endcap	1	✓▲	✓▲	✓▲
	C5	Utensil Tray	2	✓	✓	✓
	C6	R/H Side Shelf	1	✓▲	✓▲	✓▲
	C7	R/H Insert	1	✓+	✓+	✓+
	C8	Front Left Leg	1	✓	✓	✓
	C9	Rear Left Leg	1	✓	✓	✓
	C10	Front Right Leg	1	✓	✓	✓
	C11	Rear Right Leg	1	✓	✓	✓
	C12	Bottom Slat Assembly	1	✓▲	✓▲	✓▲
	C13	Base Tray	1	✓▲	✓▲	✓▲
	C14	Gas Bottle Holder	1	✓▲	✓▲	✓▲
	C15	Trolley Foot	1	✓▲	✓▲	✓▲
	C16	Hubcap	2	✓▲	✓▲	✓▲
	C17	Wheel	2	✓	✓	✓
	C18	Locknut	2	✓	✓	✓
	C19	Axle	1	✓	✓	✓
	C20	Retaining Rod	1	✓	✓	✓
	C21	Gas Bottle Strap	1	✓	✓	✓
	C22	Side Shelf Hook	2	✓	✓	✓
	C23	Side Shelf Fixing Bracket	2	✓	✓	✓
HARDWARE	D1	ST4.0x15 Screw	2	✓	✓	✓
	D2	M4x15 Bolt	4	✓	✓	✓
	D3	M5x15 Bolt	4	✓	✓	✓
	D4	Ø5 Washer	4	✓	✓	✓
	D5	M5 Nut	4	✓	✓	✓
	D6	M6x15 Bolt	24	✓	✓	✓
	D7	Ø6 Washer	4	✓	✓	✓
	D8	M6x35 Bolt	16	✓	✓	✓
	D9	1/4-20UNCx12 Bolt	6	✓	✓	✓

✦ Pre-Assembled Component

★ Quantity varies according to model purchased

▲ Appearance, size, and construction may differ according to model purchased

Parts Diagrams

Quantities vary according to model purchased. Specifications subject to change without prior notice. For more details on hardware, please see 'Hardware Reference Diagram.'

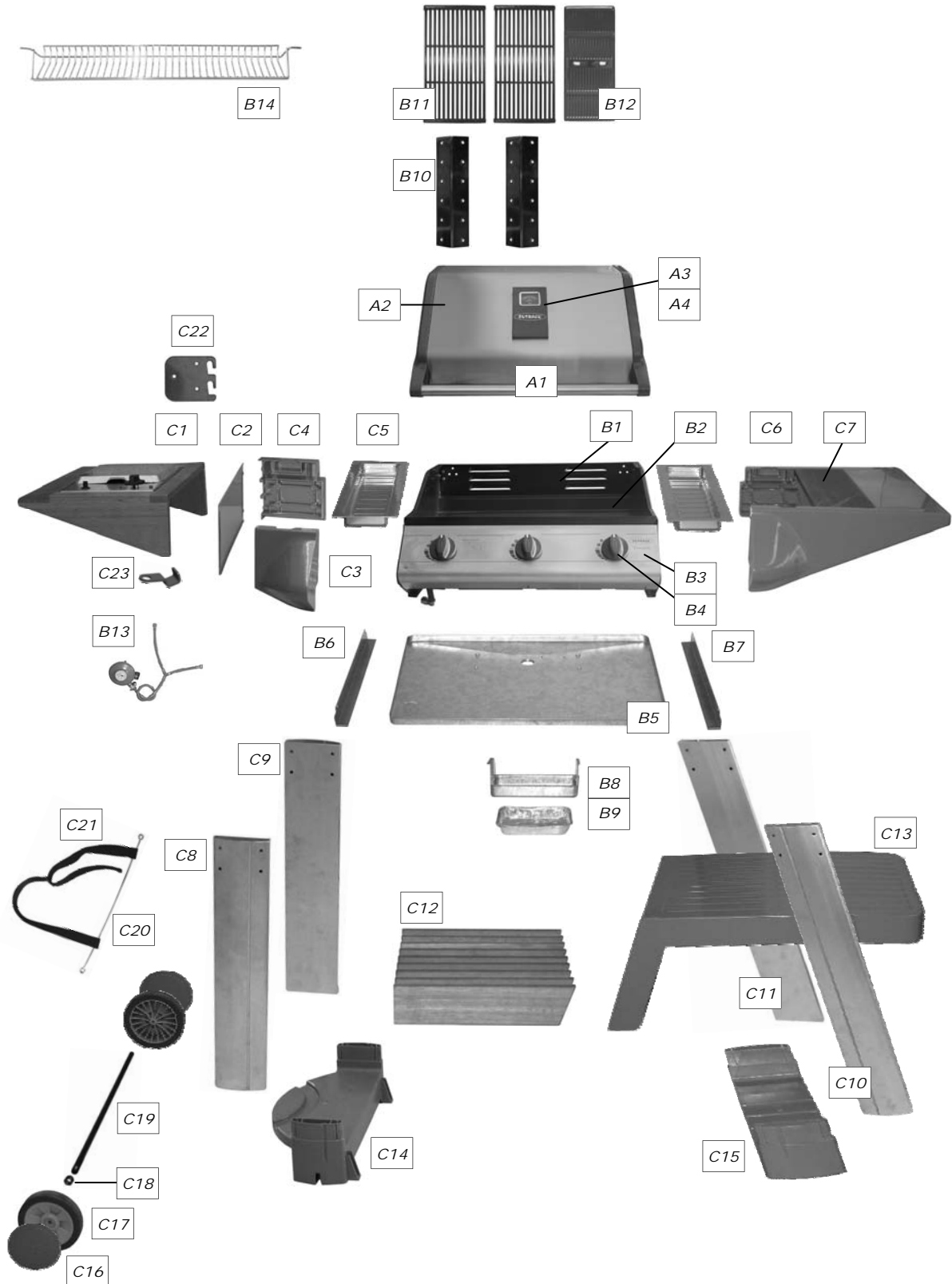

Hardware Reference Diagram

Specifications subject to change without prior notice.

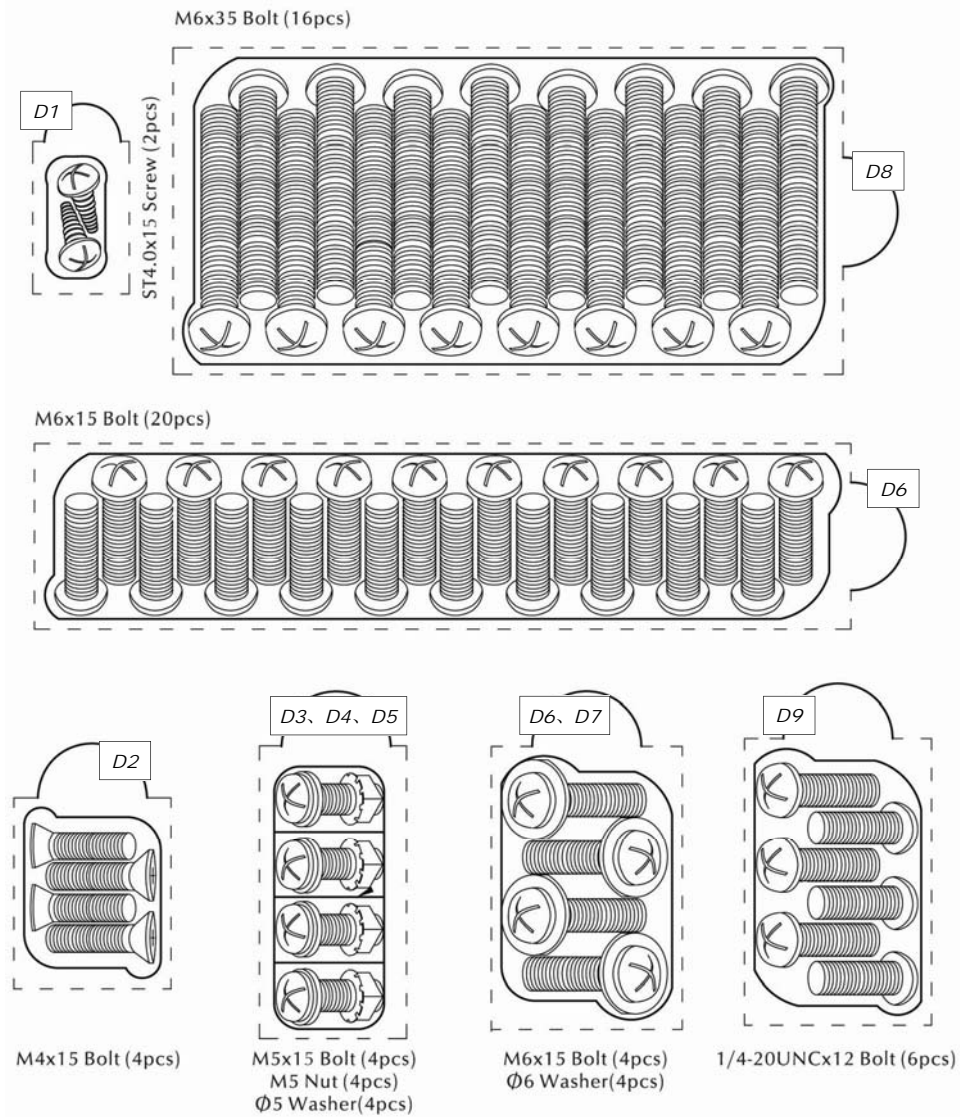

Assembly

IMPORTANT!

- **Tools Required:** Medium size flat blade or Phillips/Crosspoint screwdriver, adjustable spanner or metric spanner set
- The assembly of this barbecue requires 2 people.
- Carefully unpack the parts from the box and remove all internal packaging before commencing assembly. All loose items including the grills, griddle, flame tamers and warming basket must be removed from the body.
- The inlet connection of the gas rail assembly on the BBQ body is lower than the body. You **must never** allow the pipe to rest on the ground during assembly as serious damage could result. We recommend the body is left sitting in the box until required for assembly to trolley.
- Whilst every care is taken in the manufacture of this product, care must be taken during assembly in case sharp edges are present.

1



Attach the Rear Right Leg (C11) to the Trolley Foot (C15). The legs are a push fit onto the trolley foot and on the gas bottle holder. In case of difficulty, they may need tapping lightly with a soft face mallet. Take care not to damage parts.

2



Attach the Front Right Leg (C10) to the Trolley Foot (C15)

3

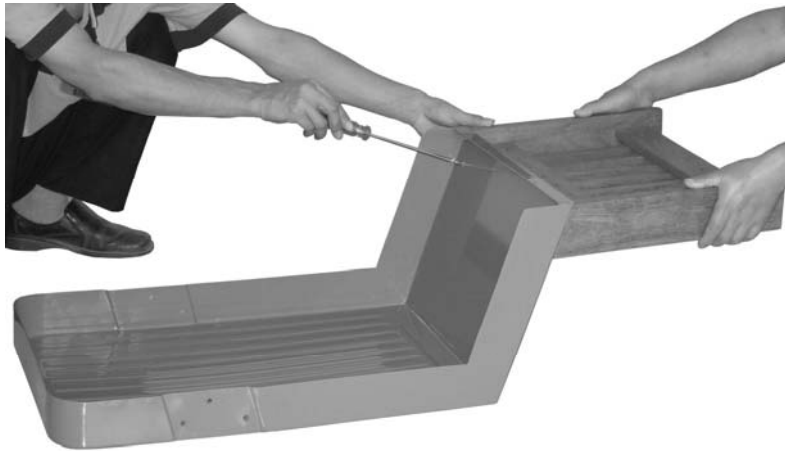

Attach the Bottom Slat Assembly (C12) to the Base Tray (C13) using the M6x15 Bolts (D6).

4

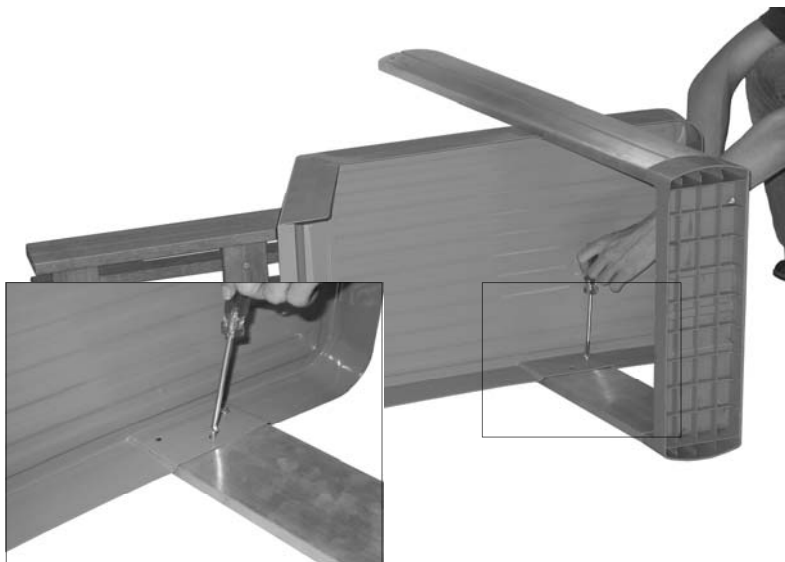

Attach the leg assembly to the Base Tray (C13) using the M6x15 Bolts (D6).

5

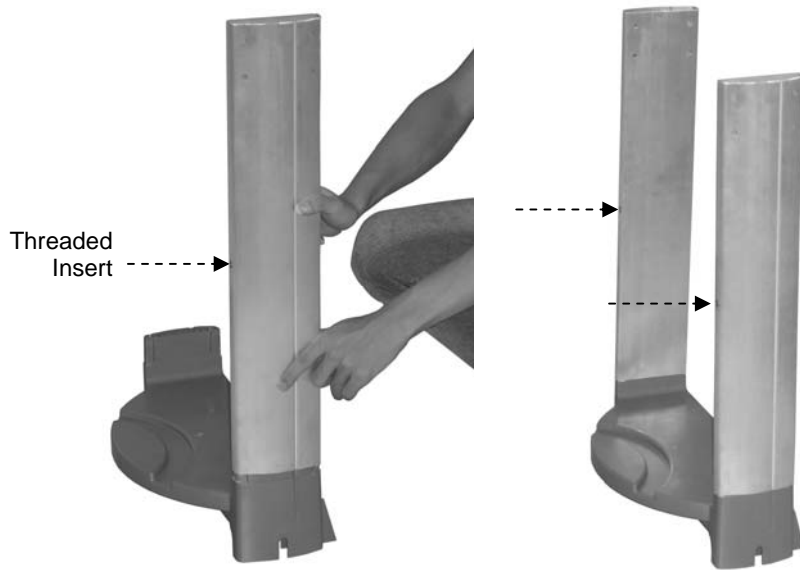

Attach the Front Left Leg (C8) and Rear Left Leg (C9) to the Gas Bottle Holder (C14).
Note: Threaded inserts must be facing in the direction shown!

6

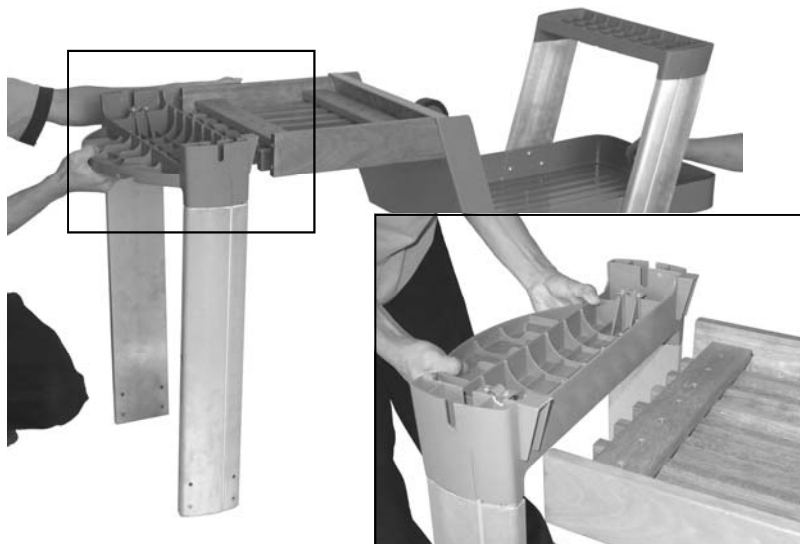

Align the Gas Bottle Holder (C14) with the Slat Assembly (C12).

7

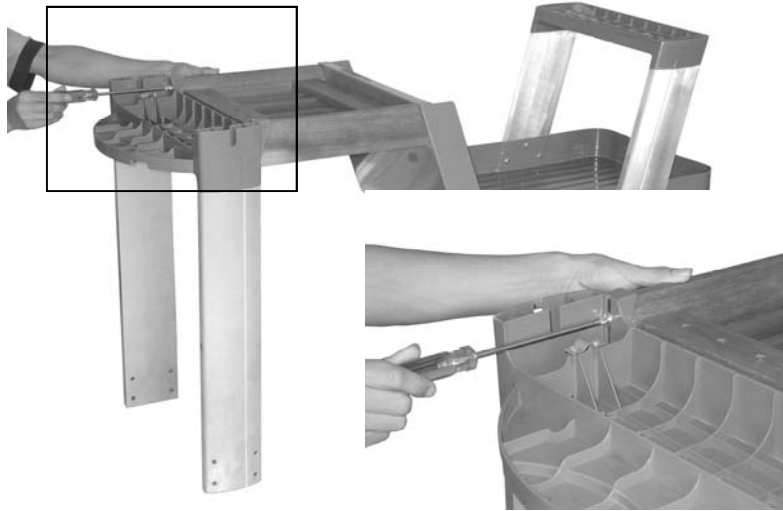

Attach the Gas Bottle Holder (C14) to the Bottom Slat Assembly (C12) using the M6x15 Bolts (D6) and Washers (D7).

8



Insert the axle (C19) through the clamping brackets on the gas bottle holder (C14) and tighten the clamp screws. Take care not to over tighten these screws which will damage the plastic Gas Bottle Holder

9

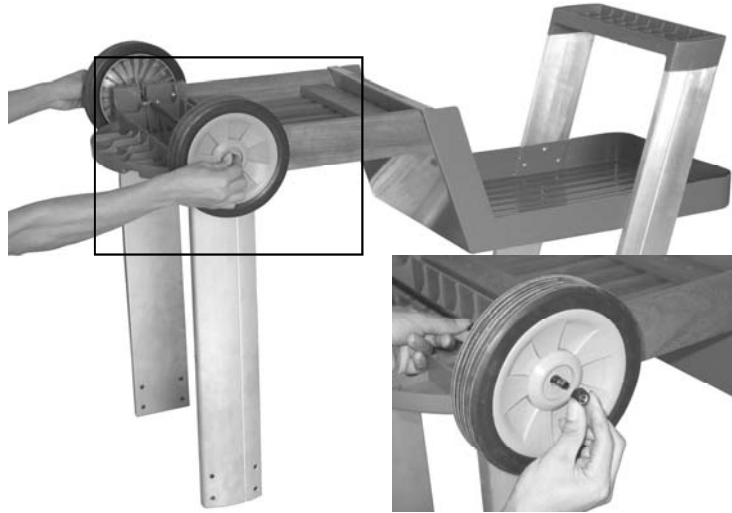

Place the Wheels (C17) onto the Axle (C19) and secure with Locknuts (C18).

10

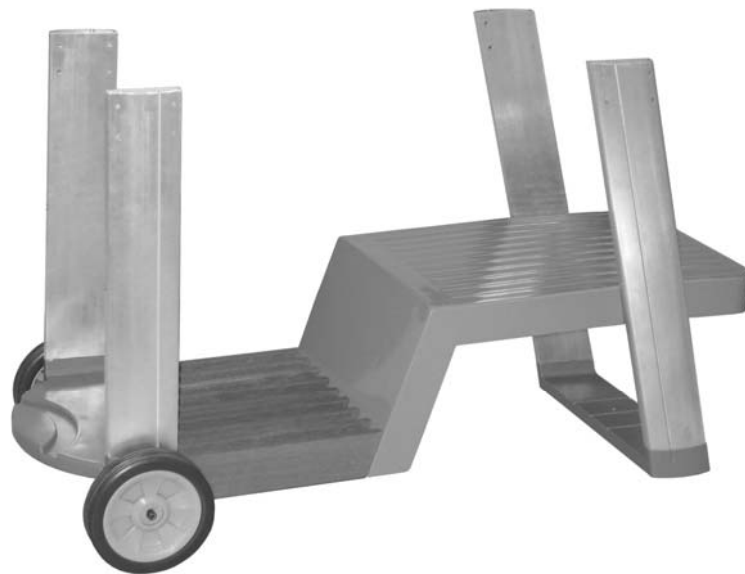

Carefully turn the completed trolley over, right side up.

11

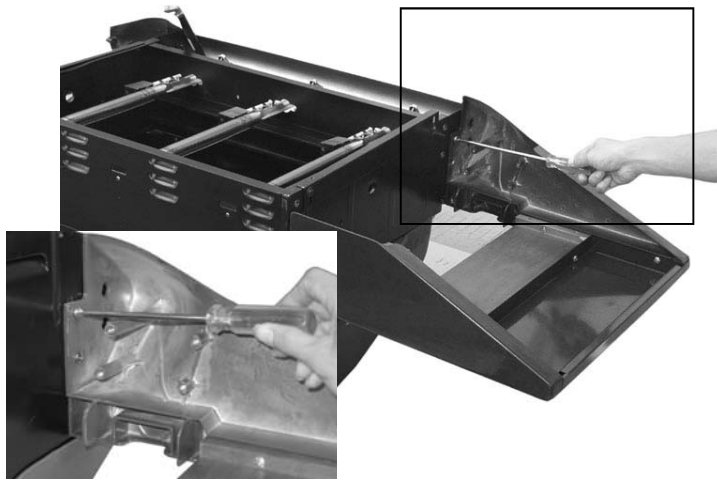

CAUTION! Care must be taken to ensure hood does not fall open unexpectedly or that the hood surface is damaged when set on the ground.

Carefully turn the Barbecue Body (B1) upside down and remove the Drip Tray (B5). Attach the R/H Side Shelf (C6) to the Barbecue Body (B1) using the M6x15 Bolts (D6).

12

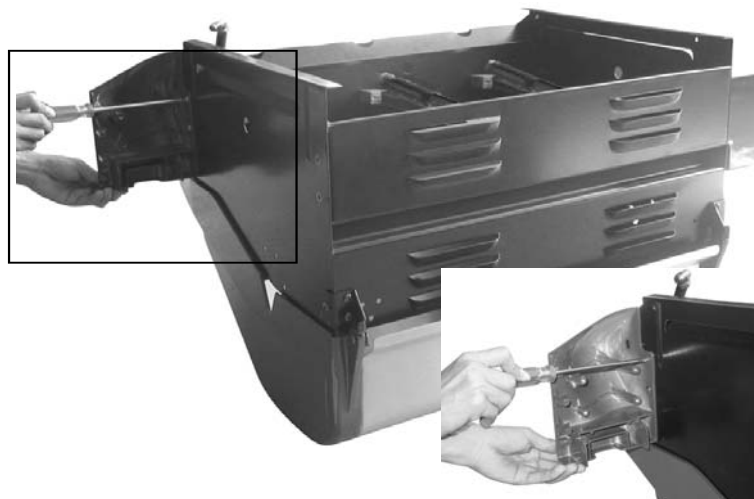

Attach the Front Left Endcap (C3) to the Body (B1) using the M6x15 Bolts (D6).

13

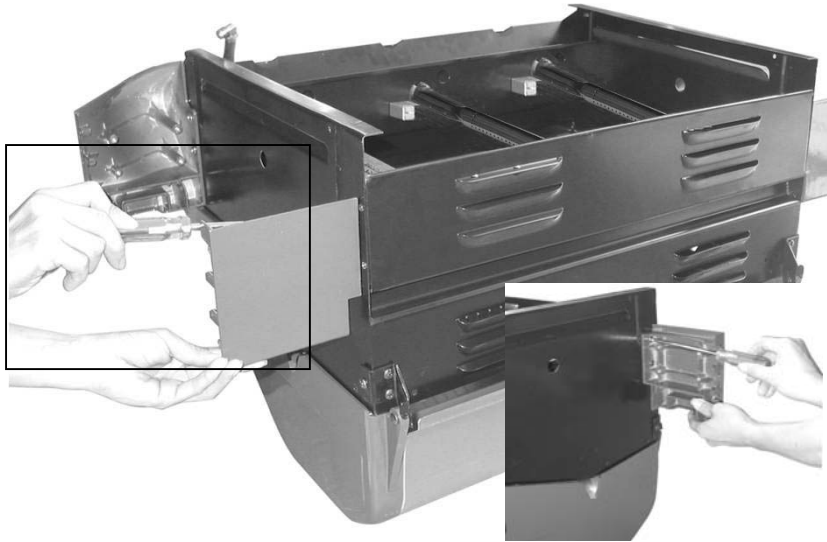

Attach the Rear Left Endcap (C4) to the Body (B1) using the M6x15 Bolts (D6).

14

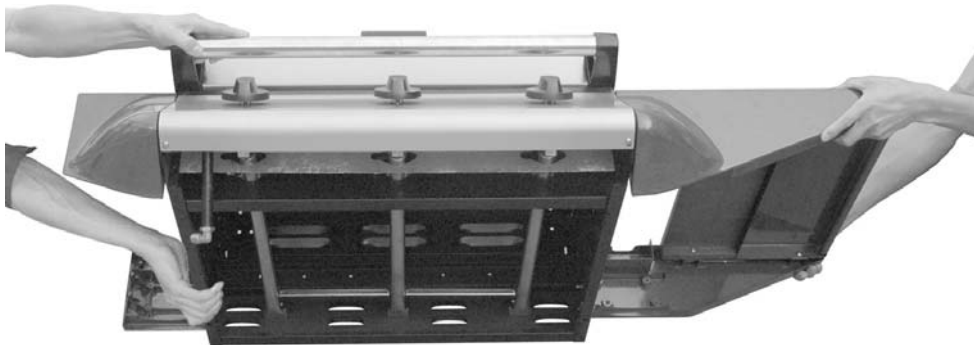

CAUTION! Care must be taken to ensure hood does not fall open unexpectedly.

Carefully turn the Barbecue Body (B1) over right-side-up.

15



Carefully lay the Barbecue Body (B1) onto the tops of the legs. The tops of the legs should slot into the endcaps. When done correctly, the barbecue should be able to stand on its own weight.

WARNING: DO NOT RELEASE THE BARBECUE BODY WHILE THE BARBECUE HAS NOT BEEN PROPERLY SEATED. THIS MAY RESULT IN INJURY OR DAMAGE TO YOUR BARBECUE.

16

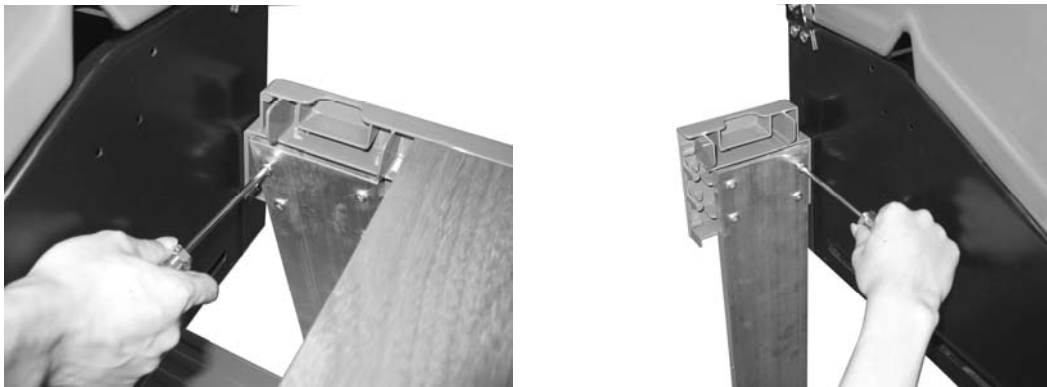

Secure the Legs (C8), (C9), (C10), (C11) to the Endcaps (C3), (C4) and the R/H Side Shelf (C6) using the M6x35 Bolts (D8).

17



Attach the Side Shelf Shield (C2) to the endcaps using the M4x15 Bolts (D2).

18

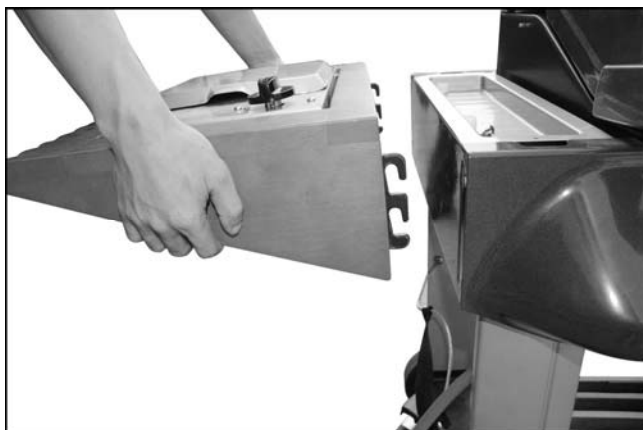
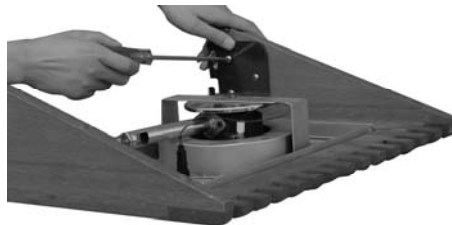

Attach the Side Shelf Hook (C22) to the Side Burner Shelf (C1) using the Bolts (D9), Hook the side burner shelf to the endcaps, Loosen the pre-assembled Fixing Brackets (C23) and Bolts (D9). Hook the Brackets to the barbecue side shelf shield, fastening the screws.

19



Lay the Utensil Trays (C5) into their positions on either side of the barbecue body.

20

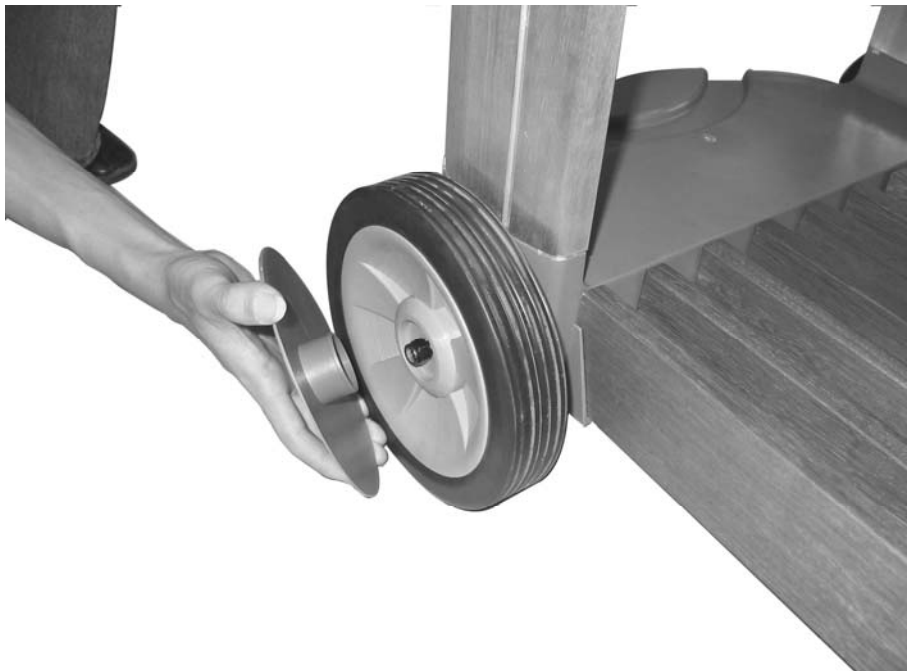

Place the Wheel Hubcaps (C16) onto the sides of the Wheels (C17)

21



Slide the loops of the Gas Bottle Strap (C21) onto the Retaining Rod (C20). Secure the Rod (C20) to the trolley legs using the M6x15 Bolts (D6).

Ensure the strap is threaded through the buckle correctly. It must hold the gas bottle firmly in place onto the barbecue.

22



Attach Drip Trip Left Bracket (B6) onto Barbecue Body (B1) by inserting M5x15 Bolts (D3) through Ø5 Washers (D4), drip trip left bracket, left sidewall of body and secure with M5 Nuts (D5). Repeat above process for Drip Trip Right Bracket (B7).

NOTE: Ensure that the tabs of the brackets which stop the drip trip are located at the front of the barbecue.

23



Insert the Drip Tray (B5) by sliding it underneath the barbecue body. Fix drip tray by inserting ST4.0x15 Screws (D1) through the hole in the middle of each drip tray bracket and screw into the drip tray.



Place the Foil Liner (B9) into the Drip Pan (B8) and slide into place.

24



Remove the plastic wrap from the Flame Tamer (B10) and lay them carefully into the body ensuring that they lie level within the body. Lay the Grills (B11) and Griddle (B12) into place.

2 Burner Configuration: Left half - Grill, Flame Tamer; Right half - Grill, Flame Tamer;
3/6 Burner Configuration: Left two-thirds - Grills, Flame Tamer; Right third - Griddle;

NOTE: The flame tamers must be laid over the burners.

25

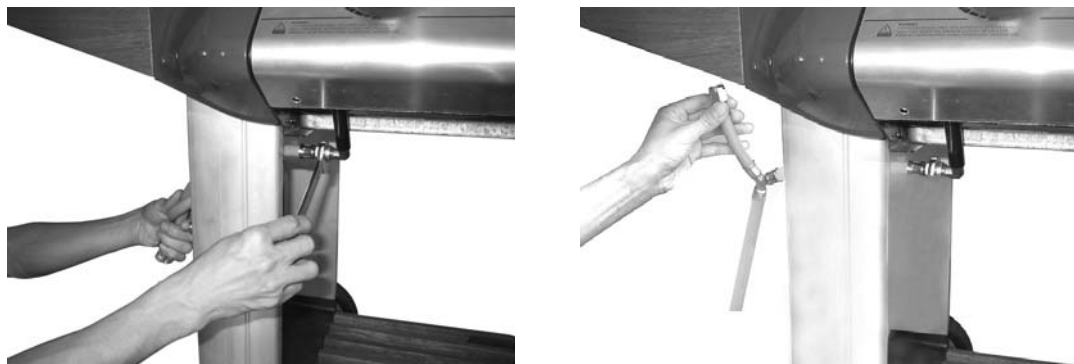

Connect the Hose and Regulator (B13) to the barbecue and side burner. Ensure the mating faces of the connection are clean and not damaged. Do not use any sealing tape, paste, or liquid on the joint. The nut must be tightened with the use of a spanner. Do not use force which may damage the assembly.

26

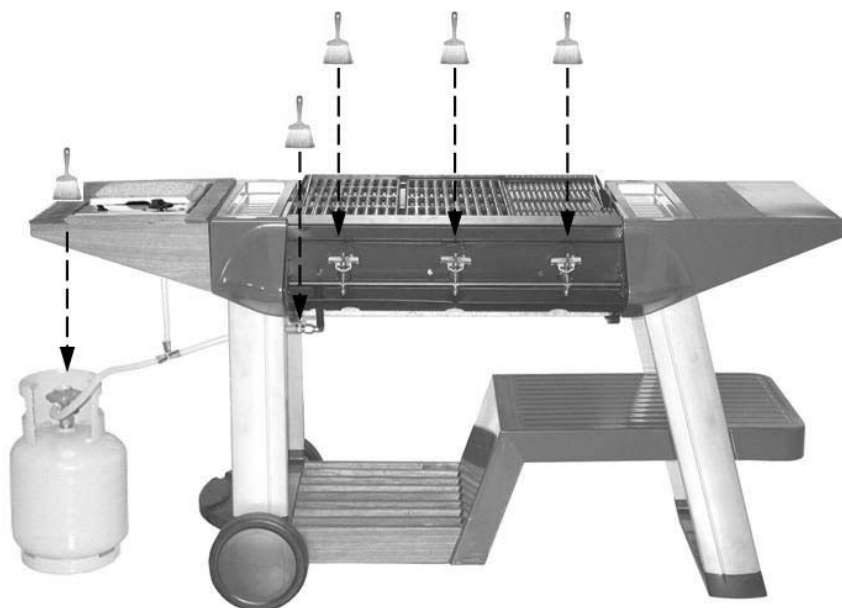

Assembly is now complete.
All joints and connections must now be **leak tested** before using the barbecue.
For details of leak testing, please refer to instructions on Page 20.
Number of valves to be leak tested will vary with model of barbecue.

▲ ESSENTIAL INFORMATION

Please read instructions before using your barbecue.

BEFORE YOU USE YOUR BARBECUE (also see installation)

- Perform a leak test. This is the only safe and sure way to detect any gas leaking from joints and connections of the barbecue after assembly. Follow the leak test instructions on page 20. Check that the gas hose is free of any tension, twisting, cuts, or cracks.
- Make sure your barbecue is in a safe place. It must be outdoors, on level ground and not below ground level. Ensure that the barbecue is at least 1 meter away from any flammable materials, including trees and fences and that there are no heat sources near the barbecue (cigarettes, open flames, spark etc.)
- Check that you have the correct gas bottle and regulator for your barbecue (see recommendations in the Gas and Regulator section of this manual) and that the gas bottle is placed correctly in the gas bottle holder provided. Never place the gas bottle directly underneath the barbecue.

GETTING STARTED (also see operation)

- Open the hood of your barbecue. Never light your barbecue with the hood closed. Turn the gas regulator or gas bottle valve to the "On" Position. Push in the control knob of the burner you want to light and turn it anti clockwise until resistance is met. Wait 4 seconds and then continue turning the control knob until a click is heard. If the burner does not light, turn off the gas by pushing and holding in the control knob at the High position and turning to "Off". The lighting sequence can then be repeated 4-5 times until the burner is lit. Ignite any of the remaining burners in any order, as needed. Confirm each burner is lit before igniting another burner. If any burner fails to ignite after following the above procedure, turn all the knobs to the "Off" position. Shut the gas off at the gas bottle or regulator. Wait 5 minutes before reattempting the above lighting procedure. If the barbecue still fails to light, please refer to the manual lighting instructions.
- Once the burners are lit, turn all the burners to the high setting for 3-5 minutes to pre-heat the barbecue. This should be done before each session. When pre-heating is complete, cooking can begin taking extra care if the burners are used in the high position.
- To prevent food sticking we recommend that you use a long handled brush to apply a light coat of cooking oil to the grills and griddles before each barbecue session.
- Side Burner - Open the lid of the side burner. Never light the side burner with the lid closed. Turn the gas regulator or gas bottle valve to the 'on' position. Push the side burner control knob in and turn it to the high position. Push and hold in the igniter button in the centre of the control panel for 4 to 5 seconds to light the burner. IF THE BURNER FAILS TO LIGHT, TURN OFF THE GAS AT THE BURNER, WAIT 5 MINUTES AND TRY AGAIN. If the burner cannot be lit using the ignition system, turn to the manual lighting instructions on page.20.
- If a fat fire should occur during cooking, and if safe to do so, turn off the burners and the gas at the gas bottle and wait for the fire to go out. Do not pull out the drip tray or douse with water.
- Never douse a barbecue with water.
- Never move a barbecue when lit.
- Never leave a lit barbecue unattended
- Never handle hot parts with unprotected hands
- Keep children, animals, and elderly people a safe distance from a lit barbecue.

WHEN YOU HAVE FINISHED COOKING (also see Maintenance)

- Turn all the burners to the high position for 3 to 5 minutes to burn off any food residue from the cooking surfaces and burners. When the barbecue has cooled, the burnt residue can be removed from the grills, griddle and flame tamers using a plastic scraper or plastic scouring pad. A brass wire brush can be used on the burners.
- When the barbecue has cooled, scrape away any food and fat residue from the drip tray and discard. Empty and clean the Foil Liner. These routines must be completed after each session.

STORAGE

- Ensure the barbecue is properly cooled.
- Always disconnect the gas bottle and store it in a safe place, never store a gas bottle indoors or on its side.
- Store the barbecue in a cool dry place. The detachable side shelf can be removed to save space during storage.

- Cover the burners with foil to keep the burner holes free from insects or other debris.
- If you intend to leave your barbecue outside make sure it is protected from the elements by a heavy duty cover, these are available from most Outback® stockists.
- Even when your barbecue is covered for its protection, it must be inspected on a regular basis as damp or condensation can form which may result in damage to the barbecue. It may be necessary to dry the barbecue and the inside of the cover. Any rust that is found that does not come into contact with the food should be treated with a rust inhibitor and painted with barbecue paint or a heat resistant paint. Wooden parts may also need to be cleaned and treated. Chrome plated warming racks etc. should be coated with cooking oil.
- The gas bottle must be always be disconnected from the barbecue and stored in a well ventilated area at least 1 metre away from any fixed ignition source. Do not store inside residential accommodation. Never store cylinders below ground level (e.g. cellars). Do not let children tamper with bottles.

IMPORTANT INFORMATION

- This product is for outdoor use only. Do not use indoors. Do not use below ground level.
- Do not store Gas bottles below ground level. LP gas is heavier than air so if a leak occurs the gas will collect at a low level and could ignite in the presence of a flame or spark.
- Do not store or use LP gas bottles on their side as this could allow liquid gas into the supply pipes with serious results.
- Leak test your barbecue annually. Check the hose connections are tight and leak test each time you reconnect the gas bottle.
- Always turn off the gas at the gas bottle when not in use.
- Do not use aerosols near this barbecue.

GAS, REGULATOR AND HOSE

This barbecue, hose, (and regulator, if included), are approved for use in the UK. The barbecue is also approved for use in other countries as listed on the control panel and in the Technical Specifications included in the barbecue manual. If the barbecue is intended to be used outside of the UK, the consumer MUST seek advice from the local qualified gas supplier as to the suitability of the barbecue and with regards to the correct hose and regulator that they should be using.

This barbecue can run on propane or butane LPG (liquid petroleum gas) bottled gas. For optimal performance we recommend the use of propane gas which is supplied under a number of different names and bottle colours. Butane gas can be used but it may restrict the heat output available from the burners, particularly when the gas temperature falls below +10 degrees Celsius. If in doubt, please consult your gas dealer/distributor.

For optimal performance, we suggest the following:

MODEL	BUTANE MINIMUM BOTTLE SIZE	PROPANE MINIMUM BOTTLE SIZE
2 BURNERS	13kg	6kg
3 BURNERS	x	10kg
6 BURNERS	x	10kg

Suitable regulator:

Butane – outlet pressure 28-30mbar

Propane – outlet pressure 37mbar The use of an adjustable regulator is dangerous and must never be used with this barbecue.

Hose

- Check that the gas hose does not touch any part of the barbecue that may become hot during operation.
- If the hose shows any sign of damage it must be replaced with a hose that is suitable for use with LPG (liquid petroleum gas) and meets British Standards.
- The length of hose should not exceed 1.5 metres.

Please note: the date on UK orange hose is the date of manufacture – not the expiry date

You must have the correct gas bottle, regulator, and hose for the barbecue to operate safely and efficiently. Use of an incorrect or faulty regulator is dangerous and will invalidate the warranty on this product. If you are unsure, please check with your local gas dealer.

INSTALLATION

Precautions:

- Only use this barbecue in a well-ventilated outdoor area.
- Check that the barbecue is not placed UNDER any combustible surface.
- The sides of the barbecue should never be closer than 1 metre to any combustible material.
- Do not obstruct any ventilation openings in the barbecue body
- Confirm all control knobs are in the off position before connecting the regulator.
- Always connect the regulator in accordance with the regulator and gas bottle suppliers instructions.

LEAK TESTING

Always perform a leak test in a well-ventilated area.

Step 1 - Confirm all control knobs are in the off position.

Step 2 - Detach the barbecue control panel located across the front of the barbecue body by pulling off the control knobs and removing the control panel retaining screws.

Step 3 - Turn on the gas at the gas bottle or regulator

Step 4 - Check for leaks by brushing a solution of ½ water and ½ liquid soap over all the gas system joints, including all valve connections, hose connections, and regulator connections.

Step 5 - If bubbles form over any of the joints there is a leak

- Turn off the gas
- Retighten all joints
- Repeat test
- If bubbles form again do not use the barbecue and contact your local Outback dealer for assistance or call Outback customer services on (01622) 671771. Customer services are available during normal office hours, Monday to Friday, 9am to 5pm.

OPERATION

Your barbecue is not designed to be used with more than 50% of the cooking area as a solid plate – this includes baking dishes. If more than 50% of your cooking area is covered by a solid cooking surface, the barbecue could overheat causing damage that is not covered by warranty.

Grill cooking

The burners heat the flame tamer beneath the grill that, in turn, heats the food. The natural juices produced during cooking fall onto the flame tamer and vaporise to form smoke. The smoke then rises and 'bastes' the food, giving it that unique barbecued flavour.

More even cooking of food will be achieved with the hood down which will also hold the heat in. This should only be done with the burners on a low to medium setting.

Griddle plate cooking

The burners heat the griddle plate directly, which then cooks the food on contact. Griddle plates enable the cooking of smaller items that would, otherwise, fall through the grill. They can also be used for searing cuts of meat or cooking food like eggs that would not be possible to cook on a grill. Griddles can also be used to heat pans.

Warming Basket

Warming baskets are a convenient way to keep cooked food warm or to warm items such as bread rolls. Care should be taken to ensure any items placed in the warming basket are cooked through and do not continue to cook and drip fat or meat juices, which could drip onto the hood and down the back of the barbecue.

Flare-up control

Flare-ups will often occur when food is barbecued as fat and juices fall onto the flame tamer. Some fat is necessary to give the food its barbecued flavour but excessive fat can result in a flare-up. To avoid flare-ups it is advisable to trim excess fat from meat and poultry before grilling, use cooking sauces and marinades sparingly, and try to avoid very cheap cuts of meat or meat products as these tend to have high fat and water

contents. Flare-ups occur more at the start of cooking, particularly with processed meat products, and it may be necessary to turn the burners down to their lowest setting to start with and then turning up at a later stage in the cooking process. The barbecue should also not be overloaded. Some parts of the cooking area are hotter than others. The hottest areas will be above the burners which will be where the flare ups will normally start. By leaving free space you can simply move the food away from the flare up to a cooler area until the flare up has subsided.

Fat Fires

The Foil Liner must be emptied and the drip tray cleaned of food debris after each cooking session. If the barbecue is to be used for commercial use or large gatherings, it will be necessary to turn off and cool the barbecue every two hours to remove food debris from the drip tray and clean out the Foil Liner, the time between cleaning may need to be reduced if very fatty foods or cheap meat products are being cooked. Failure to do this may result in a fat fire, which may cause injury and could seriously damage the barbecue.

In the event of a fat fire;

- If safe to do so, turn all control knobs to the 'off' position.
- Turn off the gas at the gas bottle.
- Keep everyone at a safe distance from the barbecue and wait until the fire has burnt out.
- Do not close the hood of the barbecue.
- **NEVER DOUSE A BARBECUE WITH WATER. IF AN EXTINGUISHER IS USED, IT SHOULD BE A POWDER TYPE.**
- **DO NOT REMOVE THE DRIP TRAY.**
- If the fire does not seem to be abating or appears to be worsening, contact your local Fire Brigade for assistance.

Manual ignition instructions

- Insert a long, lit match through the match-lighting hole in the right hand side of the body of the barbecue until the lit end is alongside the right hand burner. Push and turn the right hand control knob anti-clockwise to the high position taking care to protect yourself from flames.
- When the burner is lit turn the remaining burners from right to left.
- Confirm that each burner is lit before turning on the next burner.
- To light the side burner place the lighted end of a long match alongside the side burner. Push and turn the side burner control knob anti-clockwise to the high position taking care to protect yourself from flames.
- **If the right hand burner fails to light, turn off the gas and contact your local Outback dealer or our customer services department on (01622) 671771 for assistance.**

MAINTENANCE

- ▲ Never handle hot parts of the BBQ with unprotected hands.
- ▲ Never douse the BBQ with water when its surfaces are hot.

General

- Regularly clean your BBQ between uses and especially after extended periods of storage.
- Do not leave the BBQ uncovered and exposed to the elements when not in use. Heavy duty covers are available as an accessory from your Outback ® stockist. Even when your barbecue is covered for its protection, it must be inspected on a regular basis as damp or condensation can form which may result in damage to the barbecue. It may be necessary to dry the barbecue and the inside of the cover. Any rust that is found that does not come into contact with the food should be treated with a rust inhibitor and painted with barbecue paint or a heat resistant paint. Wooden parts may also need to be cleaned and treated. Chrome plated warming racks etc. should be coated with cooking oil.
- The wooden shelf, shelf insert and bottom slats are made from hardwood ideally suited to outside conditions. Hardwood will naturally weather and change its appearance and it is quite natural for small cracks to appear on the surface of the wood. The wood should be regularly inspected and any weathered or damaged surfaces should be recoated promptly with Yacht varnish or an external grade Polyurethane varnish. Follow the varnish manufacturer's instructions for preparation and application.
- All screws and bolts should be checked and tightened if necessary on a regular basis.

Burner Maintenance

Provided that they are operating correctly, in normal usage, burning off the residue after cooking will keep the burners clean. The burners should be removed and cleaned annually, or whenever heavy build up is found, to ensure that there are no signs of blockage (fat, debris or insects for example), in either the burner portholes or the burner primary air inlet. Use a pipe cleaner to clear obstructions. When refitting the burners, be careful to check that the neck of the burner fits over the valve outlet.

Your burners have been preset for optimal flame performance. You will normally see a blue flame, possibly with a small yellow tip when the burner is alight. If the flame pattern is significantly yellow, this could be a problem caused by grease from cooking blocking the burner or spiders or other insects in the burner venturi. This can result in the flow of the gas and air mixture being restricted or blocked which may result in a fire behind the control panel causing serious damage to your barbecue. **If this happens, the gas should be immediately turned off at the bottle.** Burners should be inspected and cleaned on a regular basis in addition to the following conditions:

- Bringing the barbecue out of storage.
- One or more of the burners do not ignite.
- The burner flame pattern is significantly yellow.
- The gas ignites behind the control panel.

To clean a burner, remove it from the barbecue. The outside of the burner can be cleaned with a wire brush.

Clean the portholes with a pipe cleaner or piece of wire. Take care not to enlarge the portholes.

Clean the insect screen on the end of the venturi tube with a bristle brush (i.e. an old toothbrush).

Clean the venturi tube with a pipe cleaner or piece of wire. You may need a torch to see into the venturi tube to make sure it is clear.

Turn the burner up on end and lightly tap against a piece of wood to dislodge any debris from inside.

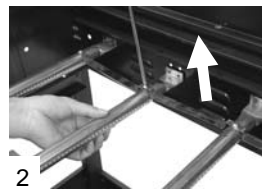

LPG Hose

The LPG hose does not have a time-limited in-service life but it is essential that the hose and end connections are regularly inspected and replaced if showing signs of:

- Physical damage such as – cuts or abrasion, cracking, stretching, flattening or kinking;
- Environmental deterioration such as – stiffening, cracking, de-lamination of outer covering, chemical degradation i.e. softening of outer coating by contact with oil;
- Hose service failure such as – blistering, soft spots, rupture or corrosion or loosening of the swaged fittings or worm drive clips attaching the hose.

Cleaning

<i>Material</i>	<i>Where used</i>	<i>Cleaning Method Recommended</i>
Stainless Steel	Centre hood panel	Clean using hot soapy water or with the use of a suitable cleaning product following the manufacturers instructions.
Porcelain enamel	Grills Griddles Hood Flame Tamers	Enamel is a thin, glass based coating fused onto metal and as such needs to be treated with care. Cooking oil, together with fat from food being cooked can turn to carbon as a result of heating and result in black flakes coming away from the cooking surfaces. These are not harmful. Porcelain should be cleaned using hot soapy water or with the use a suitable cleaning product following the Manufactures instructions. Due to the weight of the grills and griddle, we do not recommend cleaning in a dishwasher.
Chromium plated	Warming rack	Wash with hot soapy water. A chrome cleaner may be used if required. To prevent rusting, wipe with cooking oil after rinsing and drying.
Wood	Shelves and shelf inserts	Wipe with a cloth wrung out in hot soapy water and dry.
Plastic Paint	Trolley excluding wooden shelving Body Utensil trays	Wipe with a cloth wrung out in hot soapy water and dry. Excess fat and food debris can be removed from inside the body using a plastic or wooden scraper. Do not use abrasives. If rust appears on the body it should be treated with a suitable rust inhibitor and painted with a heat resistant paint.
Galvanised	Drip tray Foil Liner	Excess fat and food debris must be removed using a plastic or wooden scraper. This needs to be carried out between each use of the BBQ. Excessive build up is likely to lead to a fat fire which can be hazardous and damage the BBQ. This is not a fault in the BBQ and therefore is not covered by the terms of the warranty. If required, the tray and foil liner can be washed in hot soapy water.
Stainless Steel	Burners	Any food debris should be removed on a regular basis. For detailed burner instructions refer to MAINTENANCE on Page 22.

Troubleshooting

Problem

Possible Cause

Solution

Burners will not light using the ignition system

LP gas bottle is empty

Replace with full gas bottle

Faulty regulator

Have regulator checked or replace

Obstructions in burners

Clean burners

Obstructions in gas jets or gas hose

Clean jets and gas hose

Electrode wire is loose or disconnected on electrode or ignition unit

Reconnect wire

Electrode or wire is damaged

Change electrode and wire

Faulty integral igniter

Replace gas valve complete with integral igniter

Incorrect electrode gap/
Bent collector box

The gas collector box around the electrode needs to be in line with the burner with a gap of 3 to 4mm between the end of the electrode and the tag on the end of the collector box. Realign the collector box as required.

Burner will not light with a match

LP gas bottle is empty

Replace with full gas bottle

Faulty regulator

Have regulator checked or replace

Obstructions in burners

Clean burners

Obstructions in gas jets or gas hose

Clean jets and gas hose

Low flame or flashback (fire in burner tube - a hissing or roaring noise may be heard)

LP gas bottle too small

Use larger gas bottle

Obstructions in burners

Clean burners

Obstructions in gas jets or gas hose

Clean jets and gas hose

Windy conditions

Use BBQ in a more sheltered position

Gas valve knob difficult to turn

Integral ignition system jammed
Gas valve jammed

Replace gas valve complete with integral igniter

Technical Specifications

Model Name	CE Approval	Heat Input	Burners	Injector Size	Gas / Pressure
Outback® Excelsior 2 Burner	0359 359BT899	7.92kW	2	1.05	Butane/ 28-30mbar Propane/ 37mbar
Outback® Excelsior 3 Burner	0359 359BT899	11.88kW	3	1.05	
Outback® Excelsior 6 Burner	0359 359BT899	16.68kW	6	0.85	
Side Burner	0359 359BT899	2.5kW	1	0.80	

Countries of Use:
I₃₊ (28-30/37) BE, CY, CZ, EE, FR, GR, IE, IT, LV, LT, LU, PT, SK, ES, CH, GB, RO
I_{3B/P(30)} BG, CY, CZ, DK, EE, FI, GR, HR, LV, LT, LU, MT, NL, NO, SK, SI, SE, TR, IS

For reference and correspondence, record your serial number here.
(See sticker on side of barbecue body.)

Serial No. _____

This number may be required when ordering spare parts or accessories. A part reference number may also be required where applicable.

OUTBACK UK LTD LIMITED 10 YEAR WARRANTY

OUTBACK barbecues are warranted to the original purchaser against defects in materials and workmanship. Porcelain coated barbecue bodies, porcelain coated roasting hoods and stainless steel roasting hoods are warranted for a period of ten (10) years from the date of purchase. Stainless steel burners are warranted for a period of two (2) years from the date of purchase. OUTBACK UK will, within this period, supply replacements for defective parts free of charge provided that:

- ◆ The product has not been used for trade, professional or hire purposes.
- ◆ The product has not been subjected to misuse or neglect, including fat fires and flare ups or use of a faulty or incorrect regulator.
- ◆ The product has not sustained damage through foreign objects, substances or accidents.
- ◆ The care and maintenance instructions given in your Outback manual have been followed.

This warranty is offered as an extra benefit and is in addition to the customers' statutory rights.

Outback UK does not warranty in any way the gas cylinder.

If you have any queries regarding the assembly or use of your barbecue please contact Outback UK

In the unlikely event that you experience problems with this barbecue, please contact:

Customer Service
Outback UK
Unit 2 Farleigh Hill
Tovil
Maidstone
Kent ME15 6RG

Tel: 01622 671771

Fax: 01622 673101

e-mail: customerservice@outbackuk.com

website: www.outbackuk.com

Published November 2008