



## Assembly and Operating Instructions for Outback® 2 Burner, Outback® 3 Burner, and Outback® 4 Burner Gas Barbecues



Photographs are not to scale.  
Specifications subject to change  
without prior notice.



CE  
0359



### WARNING

- For outdoor use only.
- Read instructions before using the appliance. Failure to follow instructions could result in death, serious bodily injury, and/or property loss.
- Warning: accessible parts may be very hot. Keep young children away.
- Do not move the appliance during use.
- Turn off the gas supply at the gas bottle after use.
- Any modification of the appliance, misuse, or failure to follow the instructions may be dangerous and will invalidate your warranty. This does not affect your statutory rights.
- Retain these instructions for future reference.
- Leak test your barbecue annually. Check the hose connections are tight and leak test each time you reconnect the gas bottle.

### FOR YOUR SAFETY

#### If you smell gas:

1. Shut off gas to the appliance.
2. Extinguish any open flame.
3. Open barbecue lid or hood.
4. If odour continues, discontinue use and contact your local dealer.

### FOR YOUR SAFETY

1. Do not store or use petrol or other flammable vapours or liquids in the vicinity of this or any other appliance.
2. A gas bottle not connected for use shall not be stored in the vicinity of this or any other appliance.

# A. Parts List

Quantities vary according to model purchased. Specifications subject to change without prior notice. For more details on hardware, please see 'Hardware Reference Diagram'.

	CODE	PART	QTY	Outback® 2 Burner	Outback® 3 Burner	Outback® 4 Burner
LID	A1	Lid Handle	1	✓	✓	✓
	A2	Flat Lid ( <i>Pre-Assembled to Body</i> )	1	✓+▲	✓+▲	✓+▲
BODY	B1	Burner	★	2+	3+	4+
	B2	Hose and Hose Clip	1	✓	✓	✓
	B3	Body ( <i>see Part A2: Flat Lid</i> )	1	✓+▲	✓+▲	✓+▲
	B4	Control Panel	1	✓+▲	✓+▲	✓+▲
	B5	Drip Tray	1	✓▲	✓▲	✓▲
	B6	Drip Tray Handle	1	✓+	✓+	✓+
	B7	Cooking Grill	★	1▲	2▲	1▲
	B8	Reversible Cooking Griddle	1	✓▲	✓▲	✓▲
	B9	Lava Rock Basket	★	1▲	2▲	1▲
	B10	Lava Rock ( <i>Packed in Basket</i> )	★	1+	2+	1+
	B11	Knob	★	2+	3+	4+
TROLLEY	C1	Side Shelf	2	✓	✓	✓
	C2	Short Leg Front	1	✓	✓	✓
	C3	Short Leg Rear	1	✓	✓	✓
	C4	Long Leg Front	1	✓	✓	✓
	C5	Long Leg Rear	1	✓	✓	✓
	C6	Screen	1	✓▲	✓▲	✓▲
	C7	Leg Endcap	2	✓+	✓+	✓+
	C8	Wheel	2	✓	✓	✓
	C9	Hubcap	2	✓	✓	✓
	C10	Axle	1	✓	✓	✓
	C11	Trolley Base	1	✓▲	✓▲	✓▲
HARDWARE	D1	Handle Bolt	2	✓	✓	✓
	D2	Trolley Bolt	24	✓	✓	✓
	D3	Body Support Bolt	8	✓	✓	✓
	D4	Spacer	8	✓	✓	✓
	D5	Wing Nut	8	✓	✓	✓
	D6	Locknut	2	✓	✓	✓
	D7	Washer	2	✓	✓	✓

✚ Pre-Assembled Component

★ Quantity varies according to model purchased

▲ Appearance, size, and construction may differ according to model purchased

## B. Parts Diagrams

Quantities vary according to model purchased. Specifications subject to change without prior notice. For more details on hardware, please see 'Hardware Reference Diagram.'

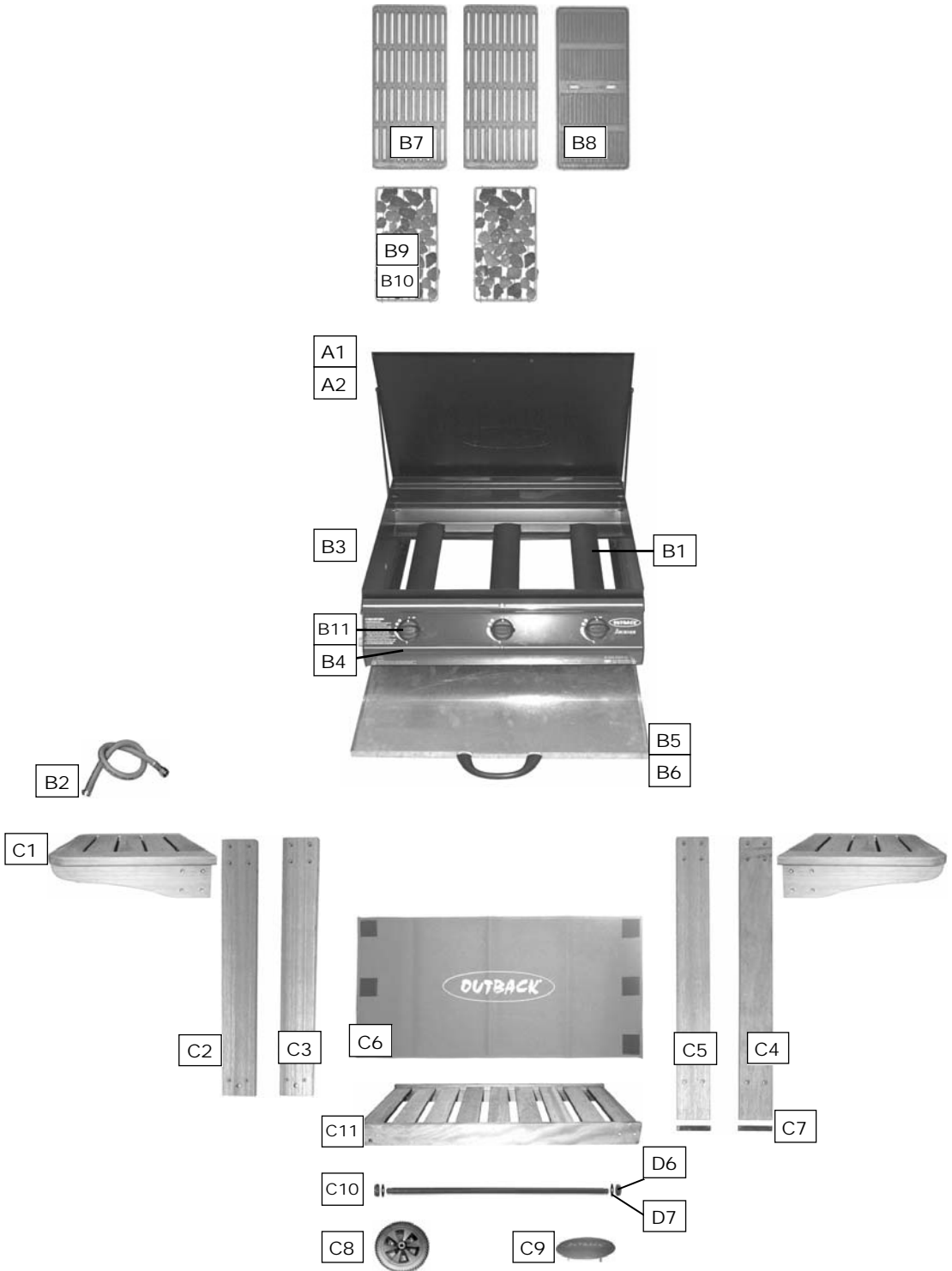

# C. Hardware Reference Diagram

Specifications subject to change without prior notice.

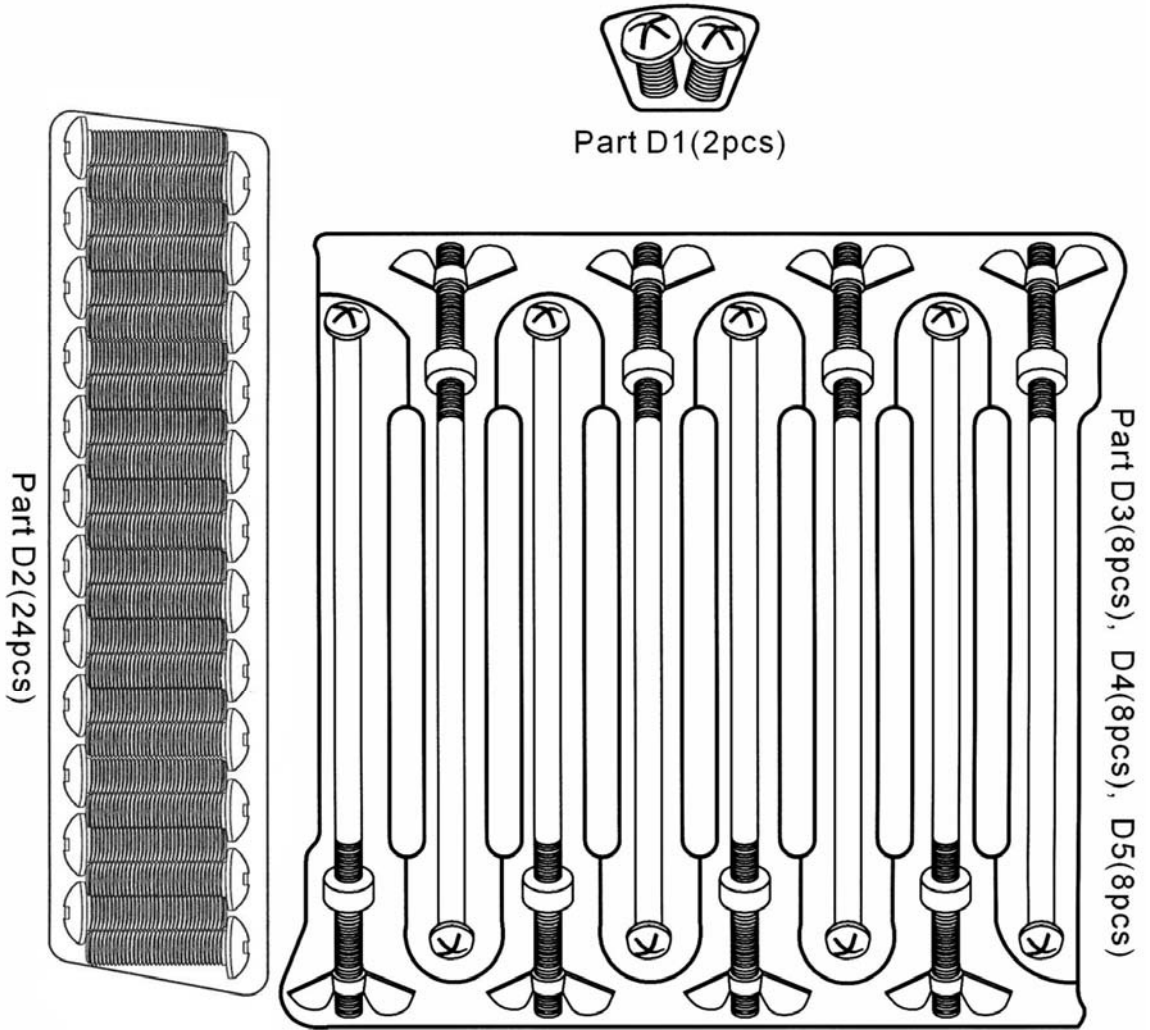

## D. Assembly

### TOOLS NEEDED FOR ASSEMBLY:

Medium size flat blade or Phillips/crosspoint screwdriver, adjustable spanner or metric spanner set

1

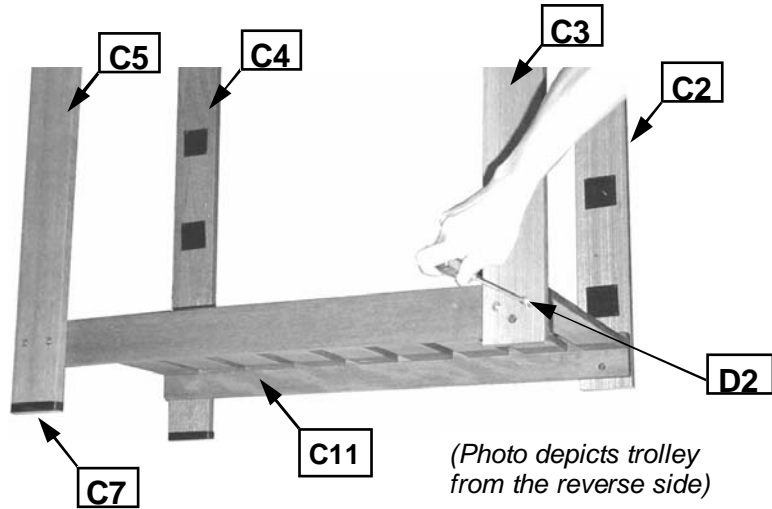

Attach the short (C2, C3) and long legs (C4, C5) to the trolley base (C11) using the trolley bolts (D2). Take care to fix the legs with Velcro attached as shown in the illustration.

2

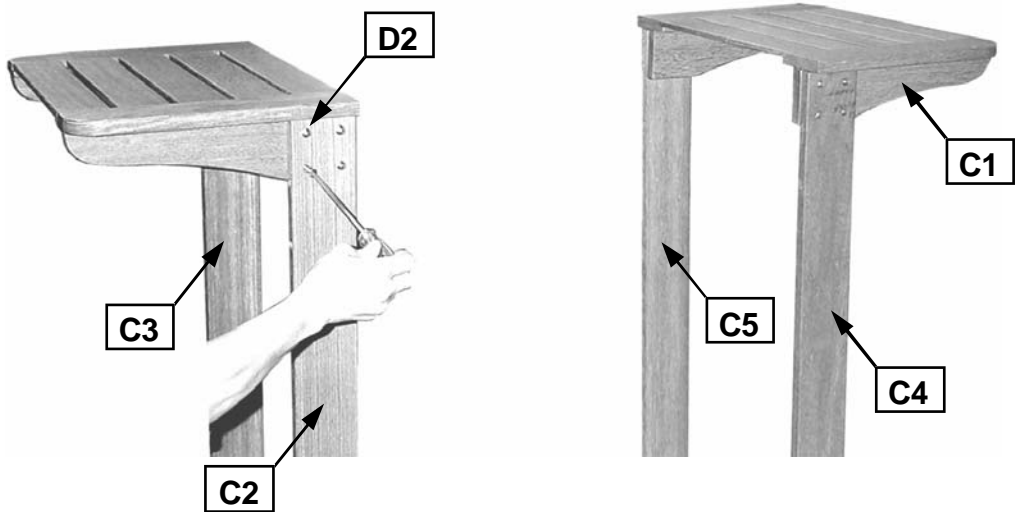

Attach the side shelves (C1) to the short (C2, C3) and long (C4, C5) legs using the trolley bolts (D2).

3

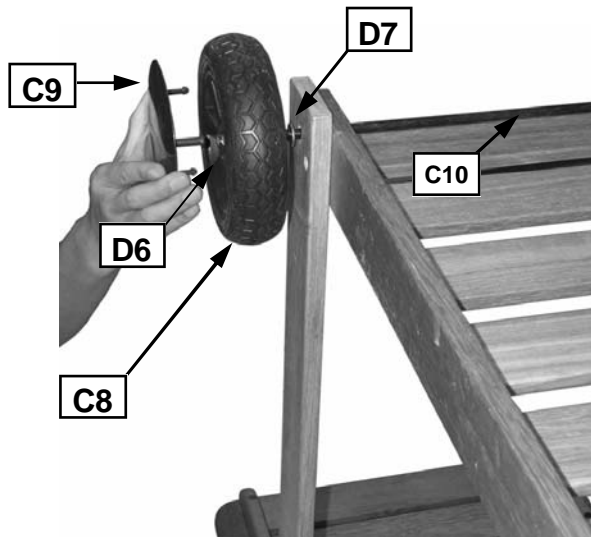

Turn the trolley over so that it stands on its side shelves. Slide the axle (C10) through the corresponding holes in the short legs. Place a washer (D7) on each end of the axle. Slide the wheels (C8) over each end of the axle. Secure the wheels into place with the locknuts (D6). Snap the hubcaps (C9) into the wheels.

4

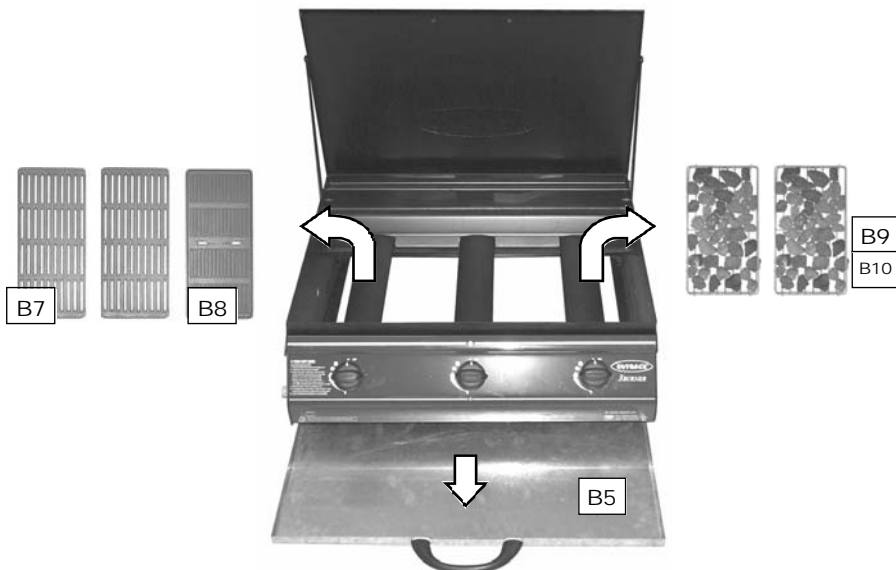

Remove all cast iron cooking components, lava rock baskets, drip tray, and any internal packaging from the barbecue body.

5

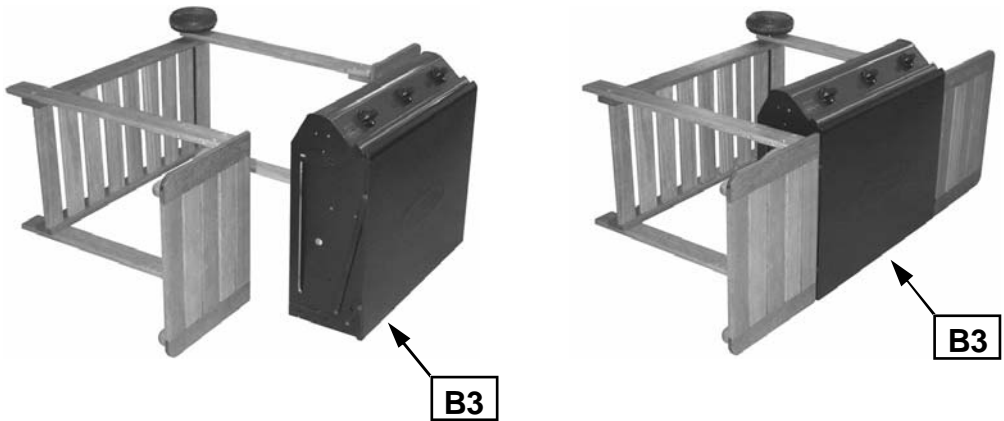

Lay the assembled trolley on its side. Lay the body (B3) on its back and slide into position between the trolley legs. **Warning:** Care must be taken to ensure lid does not fall open unexpectedly.

6

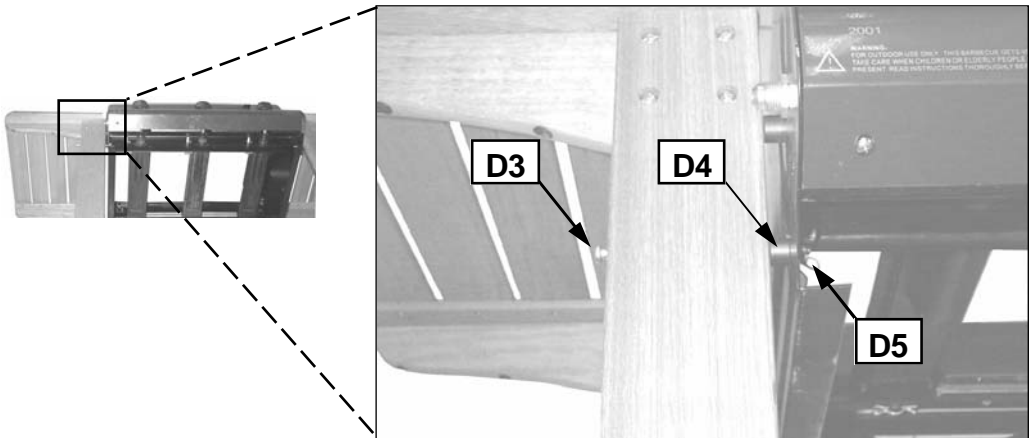

With the barbecue laid on the ground, insert a body support bolt (D3) through the short leg, through a spacer (D4), through the sidewall of the body, and secure the bolt with a wing nut (D5). Repeat the process for all the legs until the body is completely fixed to the trolley. **NOTE:** When positioning the body of the barbecue, ensure the control panel is on the same side as the legs with Velcro

7

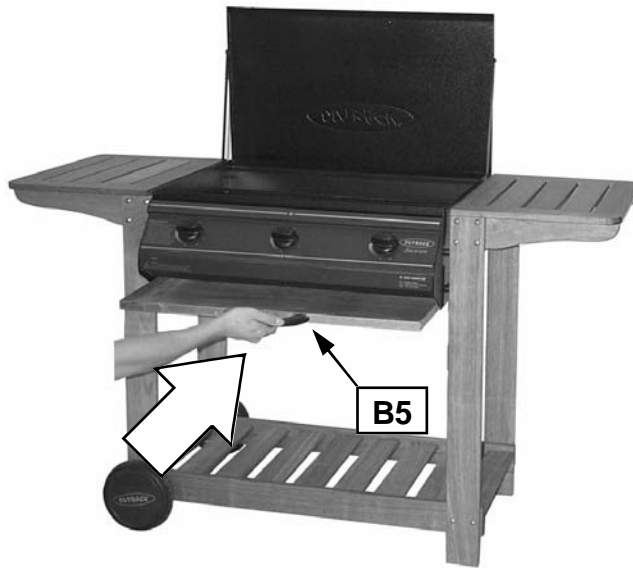

Replace the drip tray (B5) by sliding it underneath the barbecue body (B3).

8

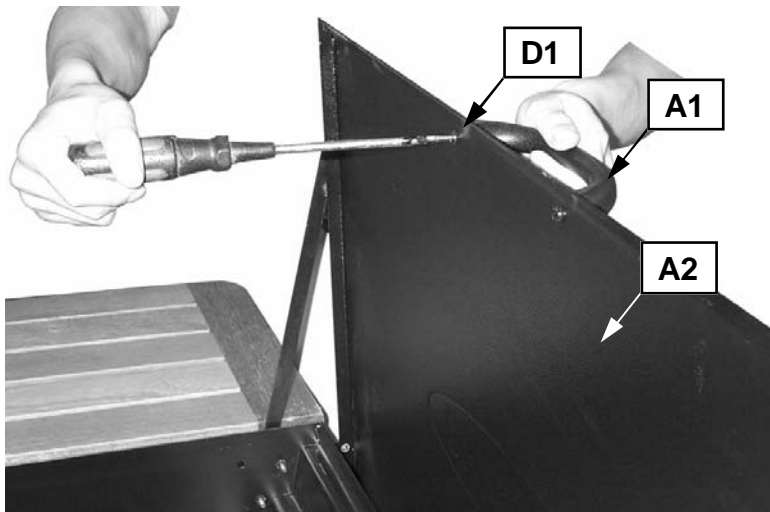

Attach the lid handle (A1) to the lid (A2) using the handle bolts (D1).

9

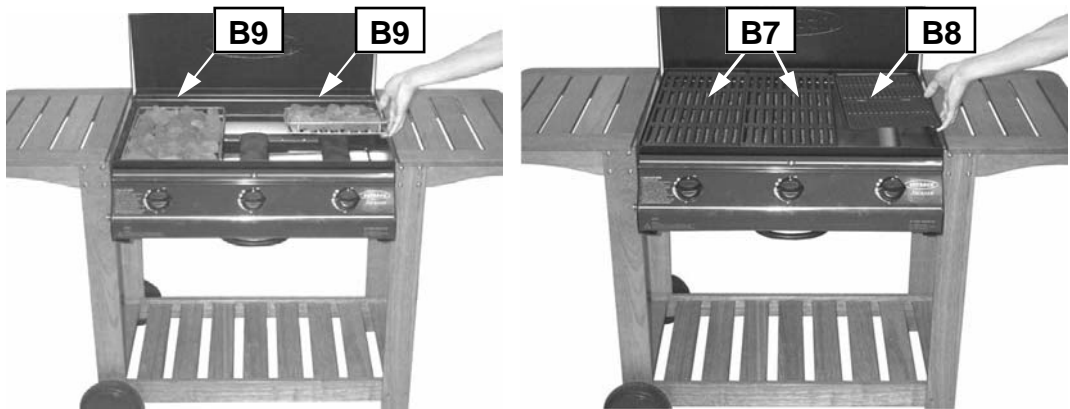

Remove the plastic wrap from the lava rock basket(s) (B9) and lay them carefully into the body ensuring that they lie level within the body. Lay the cooking grill(s) (B7) and griddle (B8) into place.

2/4 burner model configuration: Left half—Cooking Grill, Rock Basket; Right half—Griddle Plate  
3 burner model configuration: Left third—Cooking Grill, Rock Basket; Center—Cooking Grill, Rock Basket; Right third—Griddle Plate

10

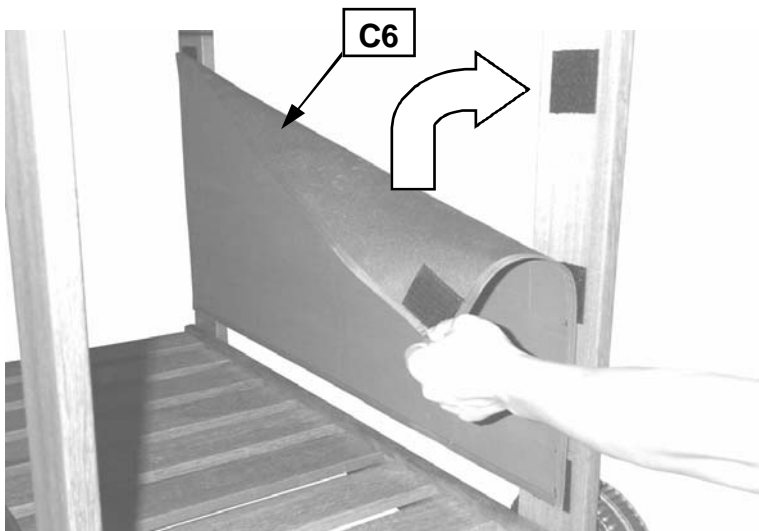

*(Rear view of the barbecue trolley.)*

## Leak Test Diagram

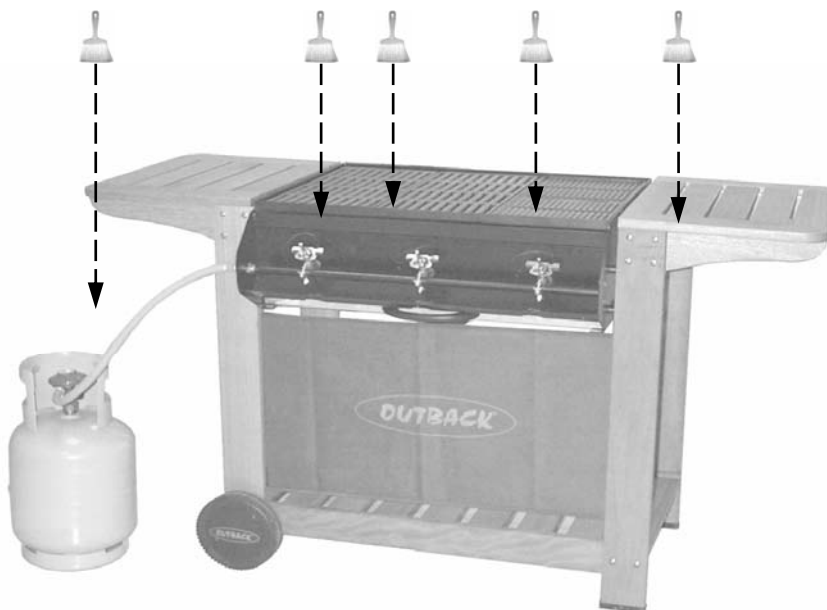

**11a.** Connect the gas hose (B2) to the barbecue (Before the Leaking Test). Ensure the mating faces of the connection are clean and not damaged. Do not use any sealing tape, paste, or liquid on the joint. The nut must be tightened with the use of a spanner. Do not use force which may damage the assembly.

**11b.** All joints and connections must now be leak tested before using the barbecue. For details of leak testing, please refer to instructions on Page 12. Number of valves to be leak tested will vary with model of barbecue.

**ASSEMBLY IS NOW COMPLETE.**

**PROCEED TO THE NEXT PAGE FOR INSTRUCTIONS ON  
OPERATION AND MAINTENANCE.**

## **E. Important Information**

**Please read these instructions carefully before assembly and use.**

- ▲ Retain these instructions for future reference.
- ▲ For outdoors use only – do not use indoors. Do not use below ground level.
- ▲ For use with LPG bottled gas only. A fixed pressure regulator of 28-30mbar must be used for butane or 37mbar for propane. The use of an adjustable regulator is dangerous and must never be used with this barbecue.
- ▲ LPG bottles should not be stored indoors.
- ▲ Remove plastic wrap from lava rock and basket before lighting.
- ▲ Do not use within 1m of any flammable structure or surface.
- ▲ LP gas cylinders should not be placed directly underneath the barbecue.
- ▲ LP gas cylinders must not be stored or used in the horizontal position. A leak would be very serious and liquid could enter the gas line.
- ▲ Open the barbecue lid before lighting. The barbecue should never be lit or used while the lid is closed.
- ▲ Do not move the barbecue while alight.
- ▲ This barbecue must not be left unattended when lit.
- ▲ Parts of this barbecue become very hot – care must be taken when children, elderly people, and animals are present.
- ▲ Always turn off the gas bottle when the barbecue is not in use.
- ▲ Never cover a barbecue until it has completely cooled.
- ▲ Leak test the barbecue annually. Check that the hose connection to the barbecue is tight and leak test whenever the gas bottle is reconnected.
- ▲ Do not store flammable materials near this barbecue.
- ▲ Do not use aerosols near this barbecue.
- ▲ Failure to follow the manual's instructions could result in serious injury or damage.
- ▲ If you have any queries regarding these instructions, contact your local dealer.

## **F. Gas and Regulator**

This barbecue, hose, (and regulator, if included), are approved for use in the UK. The barbecue is also approved for use in other countries as listed on the control panel and in the Technical Specifications included in the barbecue manual. If the barbecue is intended to be used outside of the UK, the consumer **MUST** seek advice from the local qualified gas supplier as to the suitability of the barbecue and with regards to the correct hose and regulator that they should be using.

This barbecue can run on butane or propane LPG (liquid petroleum gas) bottled gas. For optimal performance we recommend that only propane gas is used. Propane gas is supplied under a number of different names and bottle colours. Butane gas can be used but it may restrict the heat output available from the burners, particularly when the gas temperature falls below +10 degrees Celsius. If in doubt, please consult your gas dealer/distributor.

For optimal performance, we suggest the following:

<b>Model</b>	<b>Butane Minimum Bottle Size</b>	<b>Propane Minimum Bottle Size</b>
Outback® 2 Burner	15kg	6kg
Outback® 3 Burner	x	13kg
Outback® 4 Burner	x	13kg

Suitable regulators for butane must have an outlet pressure of 28-30mbar. For propane, the regulator must have an outlet pressure of 37mbar. **YOU MUST HAVE THE PROPER REGULATOR AND BOTTLE IN ORDER FOR THE BARBECUE TO OPERATE SAFELY AND EFFICIENTLY. USE OF AN INCORRECT OR FAULTY REGULATOR IS DANGEROUS AND WILL INVALIDATE ANY WARRANTY.** If in doubt, please consult your gas dealer/distributor.

## **G. Installation**

### **G1. Selecting a Location**

This barbecue is for outdoor use only and should be placed in a well-ventilated area. Take care to ensure that it is not placed **UNDER** any combustible surface. The sides of the barbecue

should NEVER be closer than 1 metre from any combustible surface. Keep this barbecue away from any flammable materials!

## **G2. Precautions**

Do not obstruct any ventilation openings in the barbecue body. Position the gas supply bottle on level ground next to the barbecue and safely away from any source of heat. Should you need to change the gas bottle, confirm that the barbecue is switched off, and that there are no sources of ignition (cigarettes, open flame, sparks, etc.) near before proceeding. Inspect the gas hose to ensure it is free of any twisting or tension. The hose should hang freely with no bends, folds, or kinks that could obstruct free flow of gas. Apart from the connection point, no part of the hose should touch any hot barbecue parts. Always inspect the hose for cuts, cracks, or excessive wear before use. If the hose is damaged, it must be replaced with hose suitable for use with LPG and meet the national standards for the country of use. The length of the hose shall not exceed 1.5m. *N.B.-The date on U.K. orange hose is the date of manufacture, not the expiry date.*

## **G3. Fixing the Regulator to the Gas Bottle**

Confirm all barbecue control knobs are in the off position. Connect the regulator to the gas bottle according to your regulator and bottle dealer's instructions.

## **G4. Leak Testing (To be performed in a well-ventilated area.)**

Confirm all control knobs are in the off position. Detach the barbecue control panel located across the front of the barbecue body by pulling off the control knobs and removing the control panel retaining screws. Open the gas control valve on the bottle or regulator. Check for leaks by brushing a solution of ½ water and ½ soap over all gas system joints, including all valve connections, hose connections and regulator connections. NEVER USE AN OPEN FLAME to test for leaks at anytime. If bubbles form over any of the joints, there is a leak. Turn off the gas supply and retighten all joints. Repeat test. If bubbles form again, do not use the barbecue. Please contact your local dealer for assistance. Leak test the barbecue annually. Check that the hose connection to the barbecue is tight and leak test whenever the gas bottle is reconnected.

# **H. Operation**

## **H1. ▲Warnings**

- ▲ Before proceeding, make certain that you understand the IMPORTANT INFORMATION section of this manual.
- ▲ This barbecue is not designed to be used with more than 50% of the cooking area as a solid plate. Full coverage of plates will cause excessive build-up of heat and damage the barbecue.

## **H2. Preparation Before Cooking**

To prevent foods from sticking to the porcelain, please use a long handled brush to apply a light coat of cooking or vegetable oil before each barbecuing session. Line the drip tray with aluminium foil, then place a uniform layer of clean, dry sand 1cm deep into the tray. This will absorb excess cooking fat, thus making cleanup easy.

## **H3. Lighting the Barbecue Using the Integra-Spark Integrated Ignition System**

- Open the lid, or open the roasting hood of your barbecue before lighting.
- Open the gas control valve on the gas bottle or regulator.
- Push the control knob of the burner you wish to light and turn it anti-clockwise until you feel resistance to the turning. Pause 4 seconds, then continue turning the control knob until a click is heard and the burner is lit. Repeat previous step 4-5 times until the burner is lit. Ignite any of the remaining burners in any order, as needed. Confirm each burner is alight before igniting another burner. If any burner fails to ignite after following above procedure, turn all the knobs to the off position. Close the gas valve on the gas bottle. Wait five minutes. Reattempt all of the above steps. If the barbecue still fails to light, please refer to the manual ignition instructions below.
- After ignition, burners should be burned at the high position for 3-5 minutes in order to preheat the barbecue. This process should be done before every cooking session. The hood or lid should be open during preheating.
- After completion of preheating, the burners should normally be turned down to a lower setting for best cooking results.

#### **H4. Manual Ignition Instructions**

- Insert lit match through the leftmost match-lighting hole on the underside of the control panel and place near leftmost burner porthole.
- Push and turn the leftmost control knob anti-clockwise to the high position.
- When the left burner is lit, turn the remaining burners on from left to right.
- Confirm that each burner is alight before turning on the next burner.
- If leftmost burner fails to ignite, contact your local dealer for assistance.
- After ignition, burners should be burned at the high position for 3-5 minutes in order to preheat the barbecue. This process should be done before every cooking session. The hood or lid should be open during preheating.
- After completion of preheating, the burners should normally be turned down to a lower setting for best cooking results.

#### **H5. Grill Cooking**

The cast iron burners heat up the lava rock underneath the grill, which in turn heats the food on the grill. The natural food juices produced during cooking fall onto the hot lava rock below and vaporise. The subsequent rising smoke bastes the food, as it travels upwards, imparting that unique barbecued flavour.

Do not attempt to cook with the lid closed. This will result in severe damage to your barbecue. Ensure all burners are turned off and the barbecue has cooled down before closing the lid.

#### **H6. Griddle Plate Cooking**

The cast iron burners heat the griddle plate directly, which then cooks the food on contact. Plates allow for the cooking of smaller items, such as seafood, which could fall through the spaces of a grill. They are also suitable for cooking items that require high-temperature/short-duration cooking, such as vegetables and smaller cuts of fish. Similarly, it can be used in exactly the same way as a griddle in the kitchen, for searing steaks, cooking eggs, etc. Alternatively, it can be used for heating pans or keeping food warm.

#### **H7. Flare-Up Control**

Flare-ups occur when meat is barbecued, and its fat and juices fall upon the hot lava rock. Smoke helps give food its barbecued flavour, but avoid excessive flare-up to prevent food being burned.

To control flare-up, it is advisable to trim away excess fat from meat and poultry before grilling. To reduce flare-ups, the burners should be turned down to the low setting. Flare-ups can be extinguished by applying baking soda or salt directly onto the lava rocks. Always protect your hands when handling anything near the cooking surface of the barbecue.

If a fat fire should occur in the drip tray, turn all knobs to the off position, turn off the gas at the bottle, and wait for the fire to go out. Do not pull out the drip tray or douse with water.

#### **H8. End of Cooking Session**

After each cooking session, turn the barbecue burners to the "high" position and burn for 5 minutes. This procedure will burn off cooking residue, thus making cleaning easier. Make sure the hood or lid is open during this process.

#### **H9. Turning Off Your Barbecue**

When you have finished using your barbecue, turn all the control valves fully clockwise to the "Off" position, then switch off the gas at the bottle. Wait until the barbecue is sufficiently cool before closing its lid.

## **I. Care and Maintenance**

Regularly clean your barbecue between uses and especially after extended periods of storage. Ensure the barbecue and its components are sufficiently cool before cleaning. Do not leave the barbecue exposed to outside weather conditions or stored in damp, moist areas.

- ▲ Never douse the barbecue with water when its surfaces are hot.
- ▲ Never handle hot parts with unprotected hands.

In order to extend the life and maintain the condition of your barbecue, we strongly recommend that the unit be covered when left outside for any length of time, especially during the winter months. Heavy-duty Outback® barbecue covers and other accessories are available from your local Outback® stockist.

Even when your barbecue is covered for its protection, it must be inspected on a regular basis as damp or condensation can form which may result in damage to the barbecue. It may be necessary to dry the barbecue and the inside of

the cover. Any rust that is found that does not come into contact with the food should be treated with a rust inhibitor and painted with barbecue paint or a heat resistant paint. Wooden parts may also need to be cleaned and re oiled. Chrome plated warming racks etc. should be coated with cooking oil.

### 11. Porcelain Coated Cast Iron Cooking Surfaces

Enamel is a thin, glass based coating fused onto metal and as such needs to be treated with care. Cooking oil, together with fat from food being cooked can turn to carbon as a result of heating and result in black flakes coming away from the cooking surfaces. These are not harmful. Porcelain should be cleaned using hot soapy water or with the use of a suitable cleaning product following the manufacturer's instructions. Due to the weight of the grills and griddle, we do not recommend cleaning in a dishwasher.

### 12. Burner Removal

Your burners have been preset for optimal flame performance. You will normally see a blue flame, possibly with a small yellow tip when the burner is alight. If the flame pattern is significantly yellow, this could be a problem caused by grease from cooking blocking the burner or spiders or other insects in the burner venturi. This can result in the flow of the gas and air mixture being restricted or blocked which may result in a fire behind the control panel causing serious damage to your barbecue. **If this happens, the gas should be immediately turned off at the bottle.** Burners should be inspected and cleaned on a regular basis in addition to the following conditions:

- Bringing the barbecue out of storage.
- One or more of the burners do not ignite.
- The burner flame pattern is significantly yellow.
- The gas ignites behind the control panel.

To clean a burner, remove it from the barbecue. It is quite normal for a cast iron burner to rust. The outside of the burner can be cleaned with a wire brush.

Clean the portholes with a pipe cleaner or piece of wire. Take care not to enlarge the portholes.

Clean the insect screen on the end of the venturi tube with a bristle brush (i.e. an old toothbrush).

Clean the venturi tube with a pipe cleaner or piece of wire. You may need a torch to see into the venturi tube to make sure it is clear. You will see a pin inside the tube which is part of the burner assembly.

Turn the burner up on end and lightly tap against a piece of wood to dislodge any debris from inside.

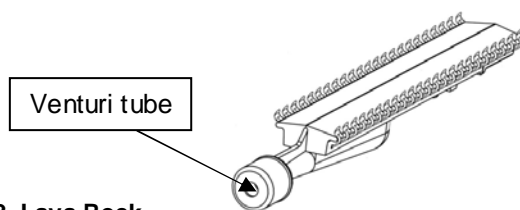
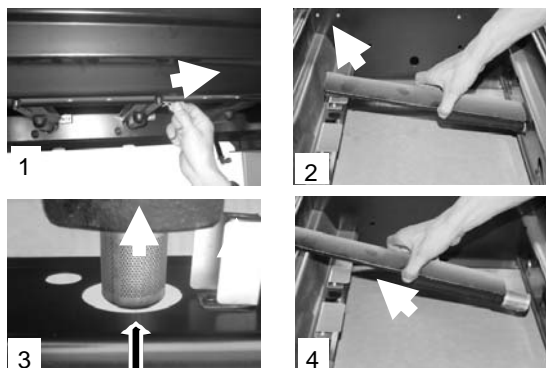

### 13. Lava Rock

It is not necessary to remove and wash the lava rock in order to keep it clean. Burning off the residue after each cooking should be sufficient. Heavily impregnated lava rock should be turned over so that the dirty side faces the burners in order to burn off any residue. Replacement lava rock is available from your local Outback® stockist.

### 14. Drip Tray

After every use, check the drip tray for fat build-up in the sand. Discard any saturated sand and replace it with fresh sand. Failure to fill with sufficient clean, dry, loose sand may result in a fat fire or excessive flare up. This can severely damage your barbecue and is not covered by the warranty.

### 15. Barbecue Body

Regularly remove excess grease or fat from the barbecue body with a soft plastic or wooden scraper. It is not necessary to remove all the grease from the body. If you need to clean fully, use hot soapy water and a cloth, or nylon-bristled brush only. Remove cooking surfaces and burners before full cleaning. Do not immerse the gas controls or manifold in water. Check burner operation after carefully refitting into body.

## 16. Trolley

Your trolley is manufactured using a hardwood suited to outdoor use, provided it is treated with Teak oil or similar after assembly and on a regular basis thereafter. Hardwood will naturally weather and change its appearance. It is quite natural for small cracks to appear on the surface of the wood.

## 17. Fixings

All screws and bolts, etc. should be checked and tightened on a regular basis.

## 18. Storage

Store your barbecue in a cool dry place. It must be inspected on a regular basis as damp or condensation can form which may result in damage to the barbecue. It may be necessary to dry the barbecue and the inside of the cover if used. Mould can grow under these conditions and should be cleaned and treated if required. Any rust that is found that does not come into contact with the food should be treated with a rust inhibitor and painted with barbecue paint or a heat resistant paint. Wooden parts may also need to be cleaned and re oiled. Chrome plated warming racks etc. should be coated with cooking oil. Wrap the burners in aluminium foil to help prevent insects or other debris from obstructing the burners.

The gas bottle must be always be disconnected from the barbecue and stored in a well ventilated area at least 1 metre away from any fixed ignition source. Do not store inside residential accommodation. Never store cylinders below ground level (e.g. cellars). Do not let children tamper with bottles.

## J. Technical Specifications

	CE Approval	Heat Input	Burners	Injector Size	Gas / Pressure
<b>Outback® 2 Burner</b>	0359 359BR128	9.5kW	2	1.12 (#44)	Butane/ 28- 30mbar  Propane/ 37mbar
<b>Outback® 3 Burner</b>	0359 359BR128	14.5kW	3		
<b>Outback® 4 Burner</b>	0359 359BR128	19.0kW	4		
<b>Countries of Use:</b> <small>1/3+(28-30/37)</small> BE, CY, CZ, EE, FR, GR, IE, IS, IT, LV, LT, LU, PT, SK, ES, CH, GB <small>1/3B/P(30)</small> CY, CZ, DK, EE, FI, GR, LV, LT, LU, MT, NL, NO, SK, SI, SE, TR <small>1/3B/P(50)</small> AT, DE, HU, SK, CH <small>1/3B/P(36)</small> PL					

Specifications are subject to change without prior notice.

## **K. Troubleshooting**

<b>Problem</b>	<b>Possible Cause</b>	<b>Solution</b>
<b>Burners will not light using the ignition system</b>	LP gas cylinder is empty	Replace with full cylinder
	Faulty regulator	Have regulator checked or replace
	Obstructions in burners	Clean burners
	Obstructions in gas jets or gas hose	Clean jets and gas hose
	Electrode wire is loose or disconnected on electrode or ignition unit	Reconnect wire
	Electrode or wire is damaged	Change electrode and wire
<b>Burner will not light with a match</b>	Faulty integral ignitor	Change ignitor
	LP gas cylinder is empty	Replace with full cylinder
	Faulty regulator	Have regulator checked or replace
	Obstructions in burners	Clean burners
<b>Low flame or flashback (fire in burner tube— a hissing or roaring noise may be heard)</b>	Obstructions in gas jets or gas hose	Clean jets and gas hose
	Obstructions in burners	Clean burners
	Windy conditions	Use BBQ in a more sheltered position
	LP gas cylinder too small	Use larger cylinder
<b>Gas valve knob difficult to turn</b>	Integral ignition system jammed	Replace gas valve
	Gas valve jammed	Replace gas valve

In the unlikely event that you experience problems with this barbeque, please contact:

Customer Service  
 Outback UK  
 Unit 2 Farleigh Hill  
 Tovil  
 Maidstone  
 Kent  
 ME15 6RG  
 Tel: 01622 671771  
 Fax: 01622 673101

e-mail: [customerservice@outbackuk.com](mailto:customerservice@outbackuk.com)

For reference and correspondence, record your serial number here. (See sticker on side of barbecue body.)

**Serial No.** \_\_\_\_\_

This number may be required when ordering spare parts or accessories. A part reference number may also be required where applicable.

Published September 2006'