



**Assembly and Operating Instructions for Outback®  
Diamond Hooded Gas Barbecues**



Photographs are not to scale.  
Specifications subject to change  
without prior notice.



0359



**WARNING**

- For outdoor use only.
- Read instructions before using the appliance. Failure to follow instructions could result in death, serious bodily injury, and/or property loss.
- Warning: accessible parts may be very hot. Keep young children away.
- Do not move the appliance during use.
- Turn off the gas supply at the gas bottle after use.
- Any modification of the appliance, misuse, or failure to follow the instructions may be dangerous and will invalidate your warranty. This does not affect your statutory rights.
- Retain these instructions for future reference.
- Leak test your barbecue annually. Check the hose connections are tight and leak test each time you reconnect the gas bottle.

**FOR YOUR SAFETY**

If you smell gas:

1. Shut off gas to the appliance.
2. Extinguish any open flame.
3. Open barbecue lid or hood.
4. If odour continues, discontinue use and contact your local dealer.

**FOR YOUR SAFETY**

1. Do not store or use petrol or other flammable vapours or liquids in the vicinity of this or any other appliance.
2. A gas bottle not connected for use shall not be stored in the vicinity of this or any other appliance.

## Parts List

Quantities vary according to model purchased. Specifications subject to change without prior notice. For more details on hardware, please see 'Hardware Reference Diagram'.

	CODE	PART	QTY	Diamond 3 Burner	Diamond 6 Burner
HOOD	A1	Hood Handle	1	✓+▲	✓+▲
	A2				
	A3				
	A4	Hood ( <i>Pre-Assembled to Body</i> )	1	✓+▲	✓+▲
	A5	Hood Panel	1	✓+	✓+
	A6	Heat Indicator and Nuts	1	✓+	✓+
BODY	B1	Barbecue Body	1	✓▲	✓▲
	B2	Burner	★	3	6
	B3	Burner Clip	★	3	6
	B4	Control Panel	1	✓+▲	✓+▲
	B5	Knob	★	3	6
	B6	Drip Tray	1	✓▲	✓▲
	B7	Drip Pan	1	✓	✓
	B8	Foil Liner	1	✓	✓
	B9	Lava Rock Basket	2	✓▲	✓▲
	B10	Lava Rock Pack ( <i>in Basket</i> )	2	✓+▲	✓+▲
	B11	Grill	2	✓▲	✓▲
	B12	Griddle	1	✓▲	✓▲
	B13	Hose/Regulator Assembly	1	✓	✓
	B14	Warming Basket	1	✓+▲	✓+▲
TROLLEY	C1	L/H Side Shelf	1	✓	✓
	C2	Side Shelf Shield	1	✓▲	✓▲
	C3	Front Left Endcap	1	✓▲	✓▲
	C4	Rear Left Endcap	1	✓▲	✓▲
	C5	Utensil Tray	2	✓	✓
	C6	R/H Side Shelf	1	✓▲	✓▲
	C7	R/H Insert	1	✓+	✓+
	C8	Front Left Leg	1	✓	✓
	C9	Rear Left Leg	1	✓	✓
	C10	Front Right Leg	1	✓	✓
	C11	Rear Right Leg	1	✓	✓
	C12	Bottom Slat Assembly	1	✓▲	✓▲
	C13	Base Tray	1	✓▲	✓▲
	C14	Gas Bottle Holder	1	✓▲	✓▲
	C15	Trolley Foot	1	✓▲	✓▲
	C16	Hubcap	2	✓▲	✓▲
	C17	Wheel	2	✓	✓
	C18	Locknut	2	✓	✓
	C19	Axle	1	✓	✓
	C20	Retaining Rod	1	✓	✓
	C21	Gas Bottle Strap	1	✓	✓
HARDWARE	D1	Countersunk Screw, M4x15	4	✓	✓
	D2	Screw, M6x15	24	✓	✓
	D3	Washer	4	✓	✓
	D4	Screw, M6x35	16	✓	✓
	D5	Screw, M5x10	4	✓	✓
	D6	Nut, M5	4	✓	✓
ROTISSERIE	E1	Rotisserie Handle	1	✓	✓
	E2	Fork	2	✓	✓
	E3	Spit Rod	1	✓	✓
	E4	Motor	1	✓	✓
	E5	L/H Bracket	1	✓	✓
	E6	R/H Bracket	1	✓	✓

✚ Pre-Assembled Component

★ Quantity varies according to model purchased

▲ Appearance, size, and construction may differ according to model purchased

## Parts Diagrams

Quantities vary according to model purchased. Specifications subject to change without prior notice. For more details on hardware, please see 'Hardware Reference Diagram.'

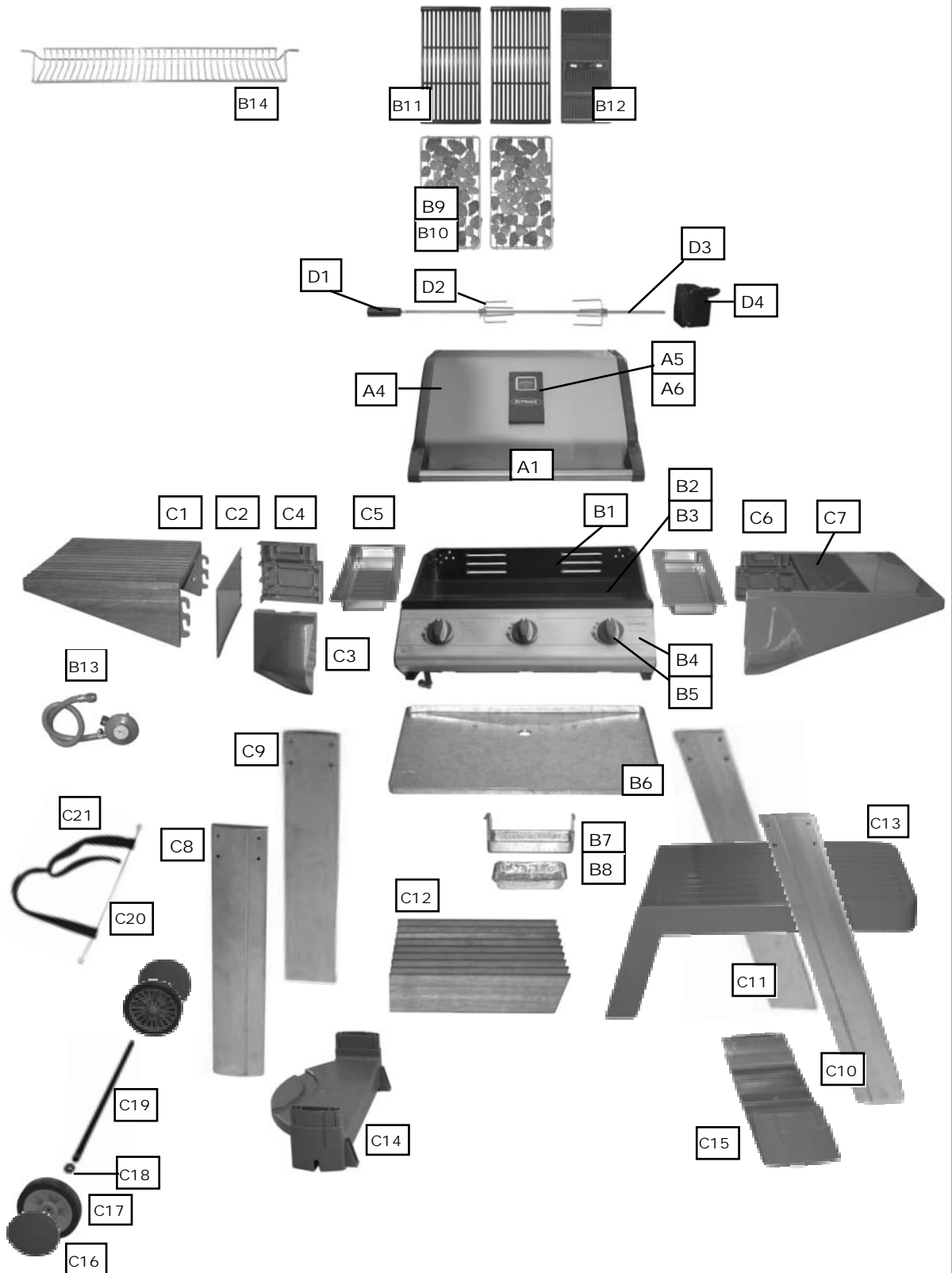

# Hardware Reference Diagram

Specifications subject to change without prior notice.

SCREW M6X35 16PCS

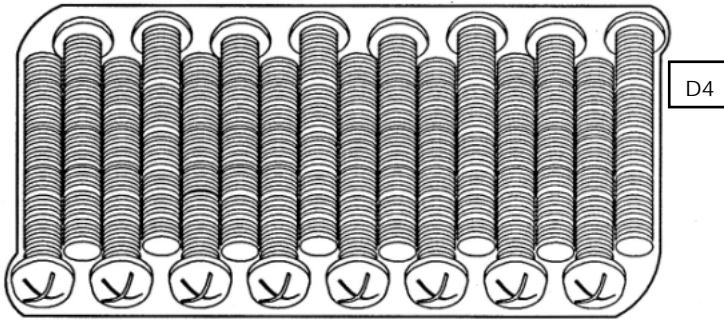

SCREW M6X15 16PCS

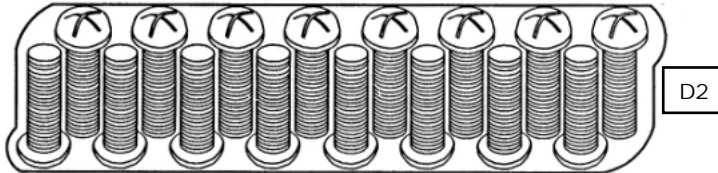

SCREW M6X15 4PCS

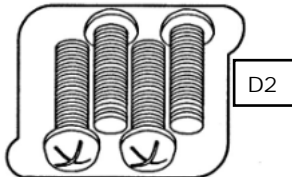

SCREW M6X15 4PCS  
WASHER  $\phi 6.5$  4PCS

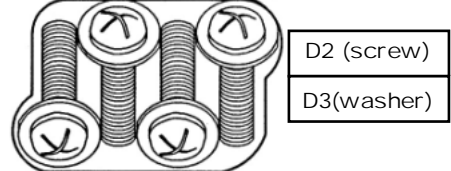

SCREW M4X15 4PCS

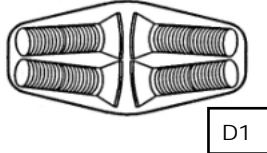

SCREW M5X10 4PCS  
NUT M5 4PCS

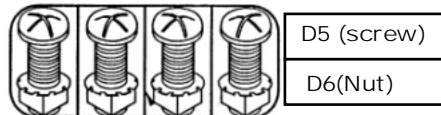

## Assembly

### IMPORTANT!

- **Tools Required:** Medium size flat blade or Phillips/Crosspoint screwdriver, adjustable spanner or metric spanner set
- The assembly of this barbecue requires 2 people.
- Carefully unpack the trolley box and remove all internal packaging before commencing assembly.
- Carefully remove the box lid from the body box and remove all internal packaging and parts inside the body.
- The inlet connection of the gas rail assembly on the BBQ body is lower than the body. You **must never** allow the pipe to rest on the ground during assembly as serious damage could result. We recommend the body is left sitting in the box until required for assembly to trolley.
- Whilst every care is taken in the manufacture of this product, care must be taken during assembly in case sharp edges are present.

1



Attach the Rear Right Leg (C11) to the Trolley Foot (C15). The legs are a push fit onto the trolley foot and on the gas bottle holder. In case of difficulty, they may need tapping lightly with a soft face mallet. Take care not to damage parts.

2



Attach the Front Right Leg (C10) to the Trolley Foot (C15)

3

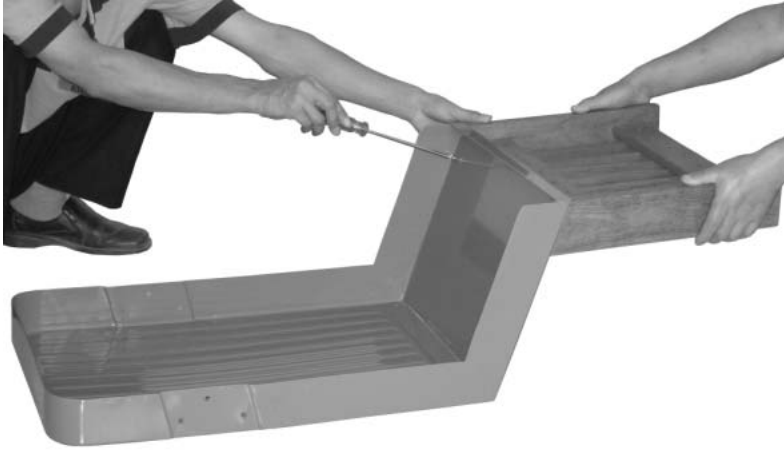

Attach the Bottom Slat Assembly (C12) to the Base Tray (C13) using the Screws (D2).

4

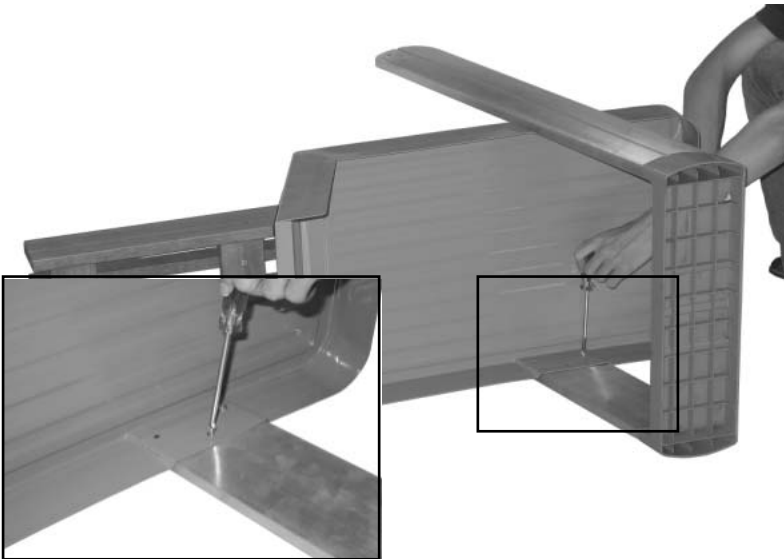

Attach the leg assembly to the Base Tray (C13) using the Screws (D2).

5

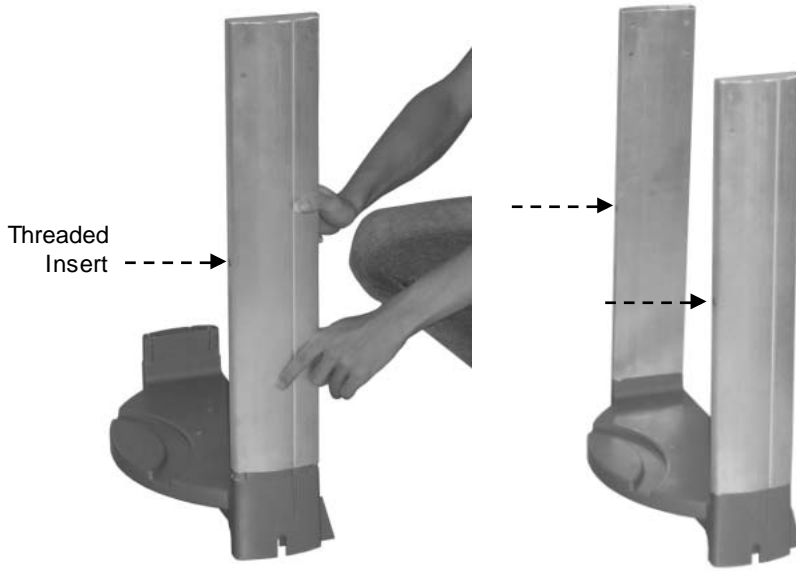

Attach the Front Left Leg (C8) and Rear Left Leg (C9) to the Gas Bottle Holder (C14).  
Note: Threaded inserts must be facing in the direction shown!

6

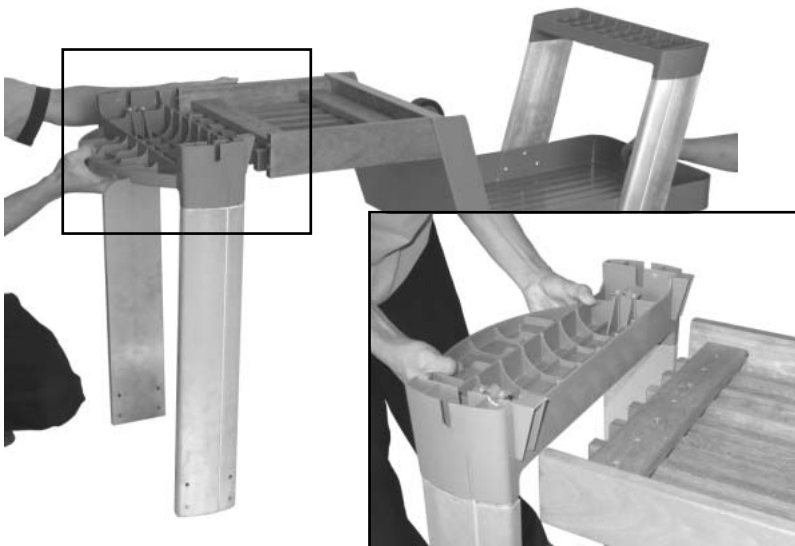

Align the Gas Bottle Holder (C14) with the Slat Assembly (C12).

7

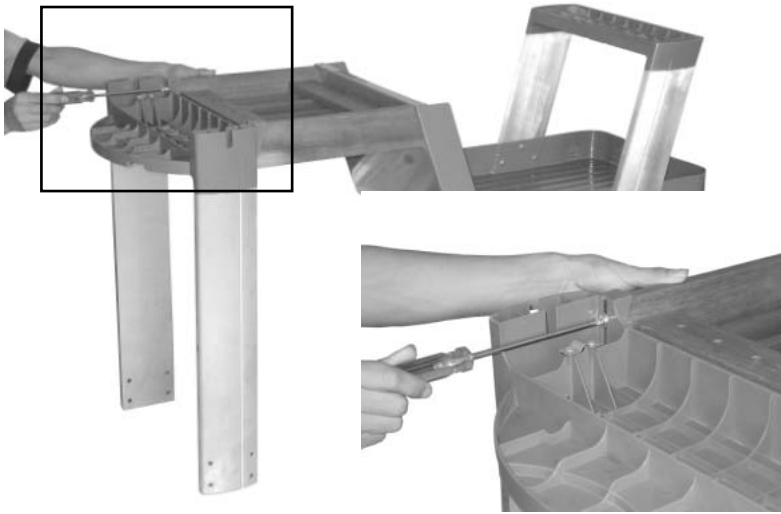

Attach the Gas Bottle Holder (C14) to the Bottom Slat Assembly (C12) using the Screws (D2) and Washers (D3).

8



Insert the axle (C19) through the clamping brackets on the gas bottle holder (C14) and tighten the clamp screws. Take care not to over tighten these screws which will damage the plastic Gas Bottle Holder

9

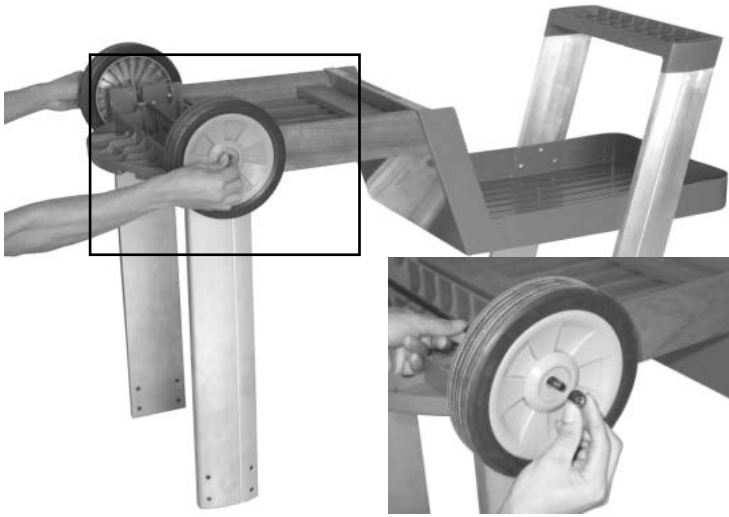

Place the Wheels (C17) onto the Axle (C19) and secure with Locknuts (C18).

10

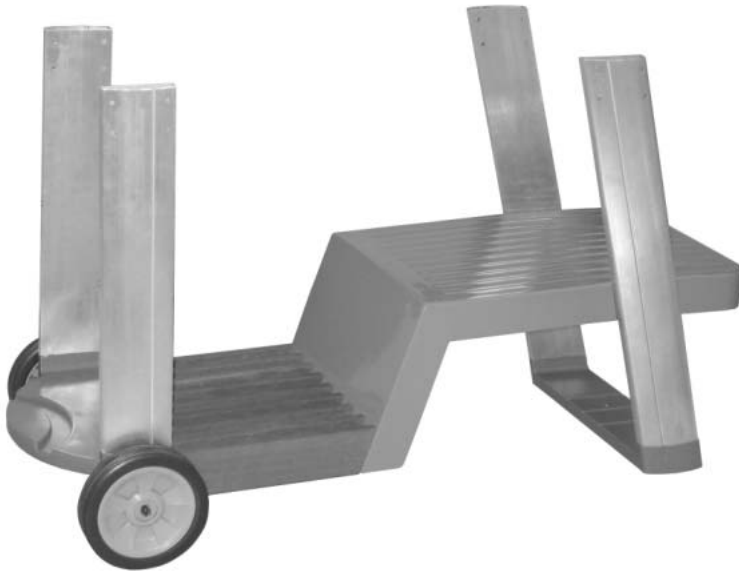

Carefully turn the completed trolley over, right side up.

11

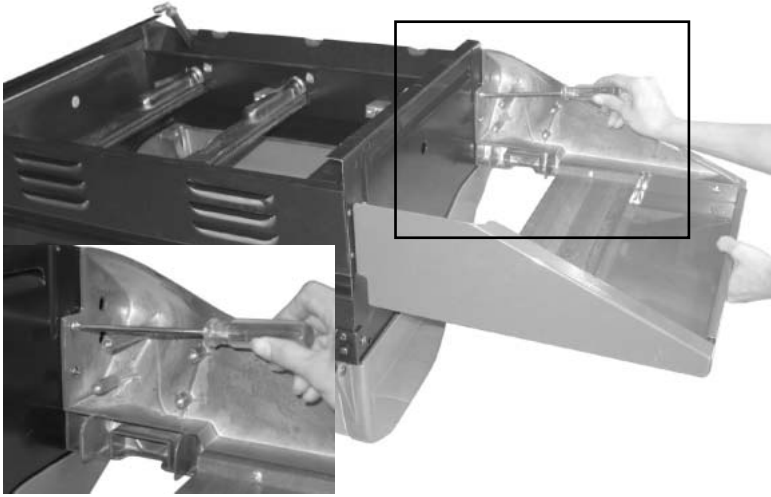

**CAUTION! Care must be taken to ensure hood does not fall open unexpectedly or that the hood surface is damaged when set on the ground.**

Carefully turn the Barbecue Body (B1) upside down and remove the Drip Tray (B6). Attach the R/H Side Shelf (C6) to the Barbecue Body (B1) using the Screws (D2).

12

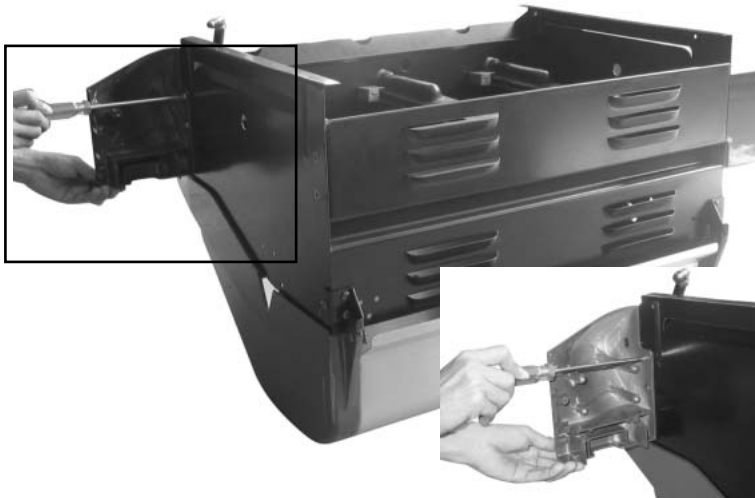

Attach the Front Left Endcap (C3) to the Body (B1) using the Screws (D2).

13

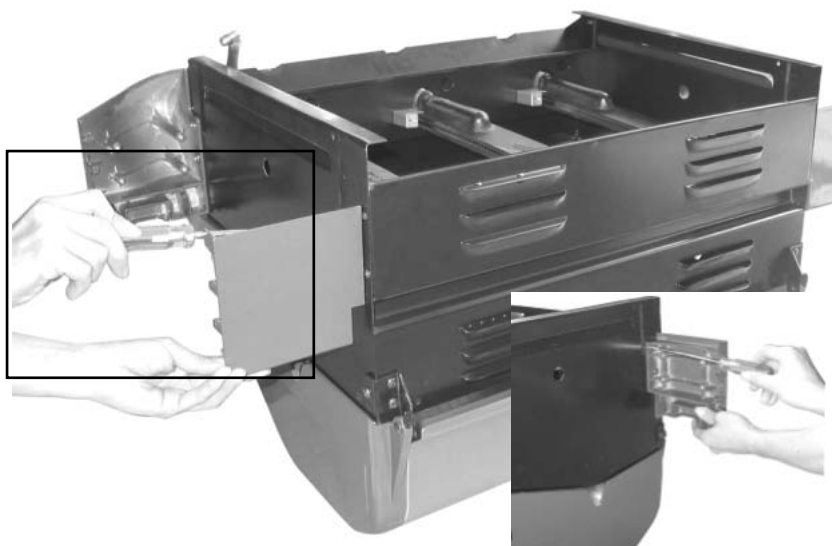

Attach the Rear Left Endcap (C4) to the Body (B1) using the Screws (D2).

14



**CAUTION!** Care must be taken to ensure hood does not fall open unexpectedly.

Carefully turn the Barbecue Body (B1) over right-side-up.

15



Carefully lay the Barbecue Body (B1) onto the tops of the legs. The tops of the legs should slot into the endcaps. When done correctly, the barbecue should be able to stand on its own weight.

**WARNING: DO NOT RELEASE THE BARBECUE BODY WHILE THE BARBECUE HAS NOT BEEN PROPERLY SEATED. THIS MAY RESULT IN INJURY OR DAMAGE TO YOUR BARBECUE**

16

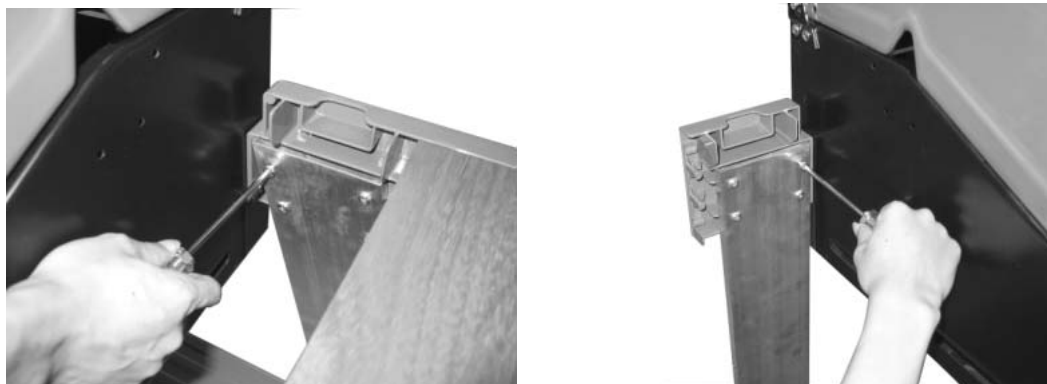

Secure the Legs (C8), (C9), (C10), (C11) to the Endcaps (C3), (C4) and the R/H Side Shelf (C6) using the Screws (D4).

17



Attach the Side Shelf Shield (C2) to the endcaps using the Countersunk Screws (D1).

18



Hook the L/H Side Shelf (C1) to the endcaps.

19



Lay the Utensil Trays (C5) into their positions on either side of the barbecue body.

20

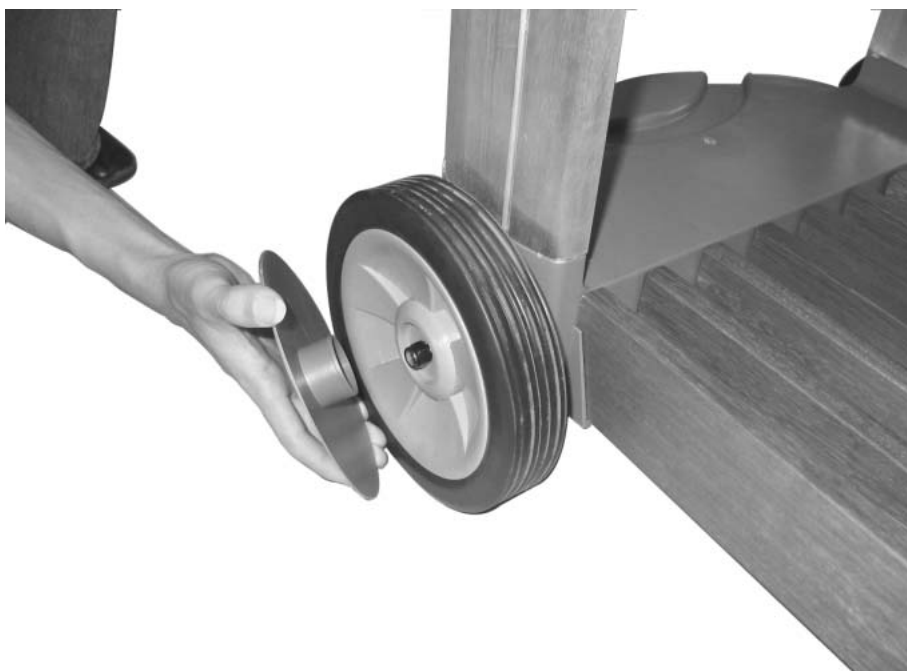

Place the Wheel Hubcaps (C16) onto the sides of the Wheels (C17)

21



Slide the loops of the Gas Bottle Strap (21) onto the Retaining Rod (C20). Secure the Rod (C20) to the trolley legs using the Screws (D2).

Ensure the strap is threaded through the buckle correctly. It must hold the gas bottle firmly in place onto the barbecue.

22



Slide the Drip Tray (B6) into place underneath the barbecue body.

23

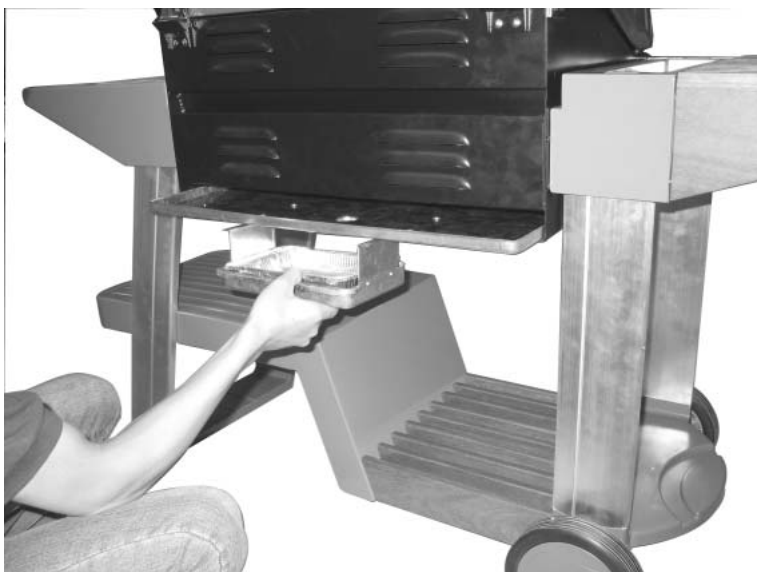

Place the Foil Liner (B8) into the Drip Pan (B7) and slide into place.

24



Remove the plastic wrap from the Lava Rock Baskets (B9) and lay them carefully into the body ensuring that they lie level within the body. Lay the Grills (B11) and Griddle (B12) into place.

3/6 Burner Configuration: Left two-thirds - Grills, Rock Baskets; Right third - Griddle  
Fit the warning basket into the hood with the lower edge of the basket facing towards the front of the barbecue.

25



Connect the gas hose (B13) to the BBQ. Ensure the mating faces of the connection are clean and not damaged. Do not use any sealing tape, paste, or liquid on the joint. The nut must be tightened with the use of a spanner. Do not use force which may damage the assembly.

26

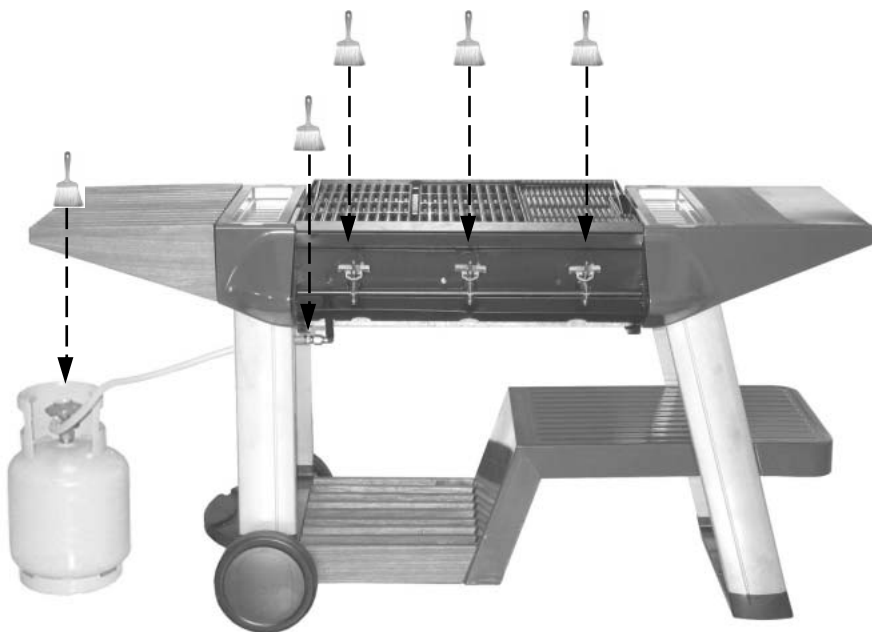

Assembly is now complete.

All joints and connections must now be **leak tested** before using the barbecue.

For details of leak testing, please refer to instructions on Page 21.

Number of valves to be leak tested will vary with model of barbecue.

## Rotisserie Kit Assembly

The rotisserie kit is packed in the barbecue trolley carton. Specifications subject to change without prior notice.

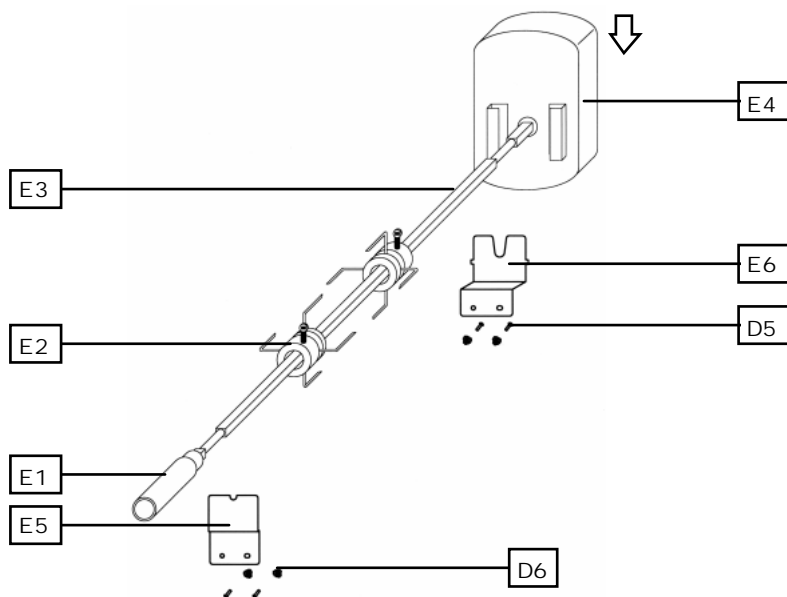

### PARTS LIST:

E1	Rotisserie Handle		
E2	Fork		2
E3	Spit Rod	1	
E4	Motor		1
E5	L/H Bracket		1
E6	R/H Bracket		1
D5	Screw, M5x10		4
D6	Nut, M5		4

### OTHER REQUIREMENTS:

2 D-Size Batteries (1.5V) (Not Included)

### ASSEMBLY:

1. Mount the R/H motor mounting bracket (E6) on the right hand side of the barbecue body. Mount the L/H mounting bracket (E5) on the other side of the barbecue body. Both brackets should point outwards from the outer sides of the barbecue body.
2. Insert batteries into motor. *N.B.* Motor can be also run using 3V DC adaptor.
3. Slide the motor (E4) onto the R/H motor mounting bracket (E6).

**NOTE:** The rotisserie motor should never be used in the event of rain. We recommend the motor is detached from the mounting bracket when not in use.

### OPERATION:

1. Carefully remove the cast iron cooking surfaces and the warming basket from the barbecue.
2. Slide the ceramic briquettes baskets to the

centre of the barbecue body. It is over this area that the meat will be cooked.

3. Slide one of the spit forks onto the spit rod and tighten its thumb screw to secure it into place. Insert the pointed end of the spit rod into the meat being cooked and slide the meat towards the centre of the rod. Make sure the fork is fully into the meat. Slide the other fork onto the rod, into the meat, and tighten the thumb screw once in place. For optimal rotisserie cooking, food must be placed securely onto the middle of the spit rod and balanced so that the rotisserie can rotate freely without interference from any barbecue surfaces. Any loose sections of meat should be secured so they do not hang down and interfere with the rotation of the spit rod. Do not overload the rotisserie. A chicken or joint of meat of approximately 2kg should be the maximum.
4. Insert the pointed end of the spit rod into the motor. Lay the other end of the spit rod onto the opposite bracket.
5. Light the grill as specified in your barbecue's instructions.
6. Turn on the rotisserie motor to begin rotisserie cooking. The hood has been designed so that it may be closed during rotisserie cooking.
7. Always cook foods on the lowest flame setting to avoid burning or overcooking.
8. The handle of the spit rod can be unscrewed to allow for simultaneous use of the side burner.

## **▲ ESSENTIAL INFORMATION**

Please read instructions before using your barbecue.

### **BEFORE YOU USE YOUR BARBECUE (also see installation)**

- Perform a leak test. This is the only safe and sure way to detect any gas leaking from joints and connections of the barbecue after assembly. Follow the leak test instructions on page 21. Check that the gas hose is free of any tension, twisting, cuts, or cracks.
- Make sure your barbecue is in a safe place. It must be outdoors, on level ground and not below ground level. Ensure that the barbecue is at least 1 metre away from any flammable materials, including trees and fences and that there are no heat sources near the barbecue (cigarettes, open flames, spark etc.)
- Check that you have the correct gas bottle and regulator for your barbecue (see recommendations in the Gas and Regulator section of this manual) and that the gas bottle is placed correctly in the gas bottle holder provided. Never place the gas bottle directly underneath the barbecue.

### **GETTING STARTED (also see operation)**

- Open the hood of your barbecue. Never light your barbecue with the hood closed. Turn the gas regulator or gas bottle valve to the 'on' position. Push in the control knob of the burner you want to light and turn it anti clockwise until resistance is felt. Wait 4 seconds and then continue turning the control knob until a click is heard. Repeat if necessary until the burner is alight. Light all other burners in the same way making sure each burner is alight before attempting to light the next. **IF ANY BURNER FAILS TO LIGHT, TURN OFF THE GAS AT THE BURNERS AND THE GAS BOTTLE, WAIT FIVE MINUTES AND TRY AGAIN.** If the burners cannot be lit using the ignition system, turn to the manual lighting instructions under important information.
- Once the burners are lit, turn all the burners to the high setting for 3-5 minutes to pre-heat the barbecue. This should be done before each session. When pre-heating is complete, cooking can begin taking extra care if the burners are used in the high position.
- To prevent food sticking we recommend that you use a long handled brush to apply a light coat of cooking oil to the grills and griddles before each barbecue session.
- Flare-ups may occur during cooking and can be controlled by applying salt directly onto the lava rock making sure your hands are protected from the heat.
- If a fat fire should occur during cooking, and if safe to do so, turn off the burners and the gas at the gas bottle and wait for the fire to go out. Do not pull out the drip tray or douse with water.
- Never douse a barbecue with water.
- Never move a barbecue when lit.
- Never leave a lit barbecue unattended
- Never handle hot parts with unprotected hands
- Keep children, animals, and elderly people a safe distance from a lit barbecue.

### **WHEN YOU HAVE FINISHED COOKING (also see Maintenance)**

- Turn all the burners to the high position for 3 to 5 minutes to burn off any food residue from the cooking surfaces and burners. When the barbecue has cooled, the burnt residue can be easily removed using a damp, non abrasive cloth on the cooking surfaces and a wire brush on the burners. Never use any abrasive material on porcelain finishes. The grills and griddles are not dishwasher safe.
- We do not recommend washing lava rock, the step described above should remove most food residue from the lava rock.
- When the barbecue has cooled, scrape away any food and fat residue from the drip tray and discard. Empty and clean the Foil Liner. These routines must be completed after each session.

### **STORAGE**

- Ensure the barbecue is properly cooled.
- Always disconnect the gas bottle and store it in a safe place, never store a gas bottle indoors or on its side.
- Store the barbecue in a cool dry place. The detachable side shelf can be removed to save space during storage.
- Cover the burners with foil to keep the burner holes free from insects or other debris.
- If you intend to leave your barbecue outside make sure it is protected from the elements by a heavy duty

cover, these are available from most Outback® stockists.

- Even when your barbecue is covered for its protection, it must be inspected on a regular basis as damp or condensation can form which may result in damage to the barbecue. It may be necessary to dry the barbecue and the inside of the cover. Any rust that is found that does not come into contact with the food should be treated with a rust inhibitor and painted with barbecue paint or a heat resistant paint. Wooden parts may also need to be cleaned and treated. Chrome plated warming racks etc. should be coated with cooking oil. Wrap the burners in aluminium foil to help prevent insects or other debris from obstructing the burners.
- The gas bottle must always be disconnected from the barbecue and stored in a well ventilated area at least 1 metre away from any fixed ignition source. Do not store inside residential accommodation. Never store cylinders below ground level (e.g. cellars). Do not let children tamper with bottles.

### **IMPORTANT INFORMATION**

- This product is for outdoor use only. Do not use indoors. Do not use below ground level.
- Do not store Gas bottles below ground level. LP gas is heavier than air so if a leak occurs the gas will collect at a low level and could ignite in the presence of a flame or spark.
- Do not store or use LP gas bottles on their side as this could allow liquid gas into the supply pipes with serious results.
- Leak test your barbecue annually. Check the hose connections are tight and leak test each time you reconnect the gas bottle.
- Always turn off the gas at the gas bottle when not in use.
- Do not use aerosols near this barbecue.

### **GAS, REGULATOR AND HOSE**

This barbecue, hose, (and regulator, if included), are approved for use in the UK. The barbecue is also approved for use in other countries as listed on the control panel and in the Technical Specifications included in the barbecue manual. If the barbecue is intended to be used outside of the UK, the consumer MUST seek advice from the local qualified gas supplier as to the suitability of the barbecue and with regards to the correct hose and regulator that they should be using.

This barbecue can run on propane or butane LPG (liquid petroleum gas) bottled gas. For optimal performance we recommend the use of propane gas which is supplied under a number of different names and bottle colours. Butane gas can be used but it may restrict the heat output available from the burners, particularly when the gas temperature falls below +10 degrees Celsius. If in doubt, please consult your gas dealer/distributor.

For optimal performance, we suggest the following:

MODEL	BUTANE MINIMUM BOTTLE SIZE	PROPANE MINIMUM BOTTLE SIZE
3 BURNERS	x	10kg
6 BURNERS	x	10kg

Suitable regulator:

Butane – outlet pressure 28-30mbar

Propane – outlet pressure 37mbar The use of an adjustable regulator is dangerous and must never be used with this barbecue.

#### **Hose**

- Check that the gas hose does not touch any part of the barbecue that may become hot during operation.
- If the hose shows any sign of damage it must be replaced with a hose that is suitable for use with LPG (liquid petroleum gas) and meets British Standards.
- The length of hose should not exceed 1.5 metres.

Please note: the date on UK orange hose is the date of manufacture – not the expiry date

**You must have the correct gas bottle, regulator, and hose for the barbecue to operate safely and efficiently. Use of an incorrect or faulty regulator is dangerous and will invalidate the warranty on this**

**product. If you are unsure, please check with your local gas dealer.**

## **INSTALLATION**

### **Precautions:**

- Only use this barbecue in a well-ventilated outdoor area.
- Check that the barbecue is not placed UNDER any combustible surface.
- The sides of the barbecue should never be closer than 1 metre to any combustible material.
- Do not obstruct any ventilation openings in the barbecue body
- Confirm all control knobs are in the off position before connecting the regulator.
- Always connect the regulator in accordance with the regulator and gas bottle suppliers instructions.

### **LEAK TESTING**

Always perform a leak test in a well-ventilated area.

**Step 1** - Confirm all control knobs are in the off position.

**Step 2** - Detach the barbecue control panel located across the front of the barbecue body by pulling off the control knobs and removing the control panel retaining screws.

**Step 3** - Turn on the gas at the gas bottle or regulator

**Step 4** - Check for leaks by brushing a solution of ½ water and ½ liquid soap over all the gas system joints, including all valve connections, hose connections, and regulator connections.

**Step 5** - If bubbles form over any of the joints there is a leak

- Turn off the gas
- Retighten all joints
- Repeat test
- If bubbles form again do not use the barbecue and contact your local Outback dealer for assistance or call Outback customer services on (01622) 671771. Customer services are available during normal office hours, Monday to Friday, 9am to 5pm.

## **OPERATION**

Your barbecue is not designed to be used with more than 50% of the cooking area as a solid plate – this includes baking dishes. If more than 50% of your cooking area is covered by a solid cooking surface, the barbecue could overheat causing damage that is not covered by warranty.

### **Grill cooking**

The cast iron burners heat the lava rock beneath the grill that, in turn, heats the food. The natural juices produced during cooking fall onto the lava rock and vaporise to form smoke. The smoke then rises and 'bastes' the food, giving it that unique barbecued flavour.

When using your barbecue for grill cooking you may wish to place the hood in the closed position which will hold the heat in to aid cooking.

### **Griddle plate cooking**

The cast iron burners heat the griddle plate directly, which then cooks the food on contact. Griddle plates enable the cooking of smaller items that would, otherwise, fall through the grill. They can also be used for searing cuts of meat or cooking food like eggs that would not be possible to cook on a grill. Griddles can also be used to heat pans.

### **Roasting (hooded barbecues only)**

If your barbecue is supplied with a roasting hood rather than a lid you are able to roast or bake in a similar way as in a conventional gas oven. For best results place the food you wish to bake or roast in a metal baking tray and set it on one side of the cooking grill. Turn the burners directly under the food to the 'OFF' position and the burners opposite the food to the 'Medium' setting. Close the hood and this will form an oven to cook the food 'indirectly'. Monitor the temperature using the heat indicator on the hood. If the internal heat becomes too high, turn the burners to the 'low' position. It is not necessary or advisable to have all of the burners on high when the hood is closed. If the hood is opened during cooking to check on the progress of the food, please allow extra cooking time for the barbecue to regain its temperature. Take care when opening the hood

as hot steam can be released on opening.

### **Warming Basket**

Warming baskets are a convenient way to keep cooked food warm or to warm items such as bread rolls. It is advisable to place food to the front of the warming basket to avoid the possibility of juices and fat running down the back of your barbecue. Always check that your warming basket is properly fitted before use.

### **Flare-up control**

Flare-ups will often occur when food is barbecued as fat and juices fall onto the lava rock. Some fat is necessary to give the food its barbecued flavour but excess fat can result in a flare-up. To avoid flare-ups it is advisable to trim excess fat from meat and poultry before grilling, use cooking sauces and marinades sparingly, and try to avoid very cheap cuts of meat or meat products as these tend to have high fat and water contents. Flare-ups can be extinguished by applying salt directly onto the flaring lava rocks, taking care to protect yourself from the flames.

### **Fat Fires**

The Foil Liner must be emptied and the drip tray cleaned of food debris after each cooking session. If the barbecue is to be used for commercial use or large gatherings, it will be necessary to turn off and cool the barbecue every two hours to remove food debris from the drip tray and clean out the Foil Liner, the time between cleaning may need to be reduced if very fatty foods or cheap meat products are being cooked. Failure to do this may result in a fat fire, which may cause injury and could seriously damage the barbecue.

In the event of a fat fire;

- If safe to do so, turn all control knobs to the 'off' position.
- Turn off the gas at the gas bottle.
- Keep everyone at a safe distance from the barbecue and wait until the fire has burnt out.
- Do not close the hood of the barbecue.
- NEVER DOUSE A BARBECUE WITH WATER. IF AN EXTINGUISHER IS USED, IT SHOULD BE A POWDER TYPE.
- DO NOT REMOVE THE DRIP TRAY.
- If the fire does not seem to be abating or appears to be worsening, contact your local Fire Brigade for assistance.

### **Manual ignition instructions**

- Insert a long, lit match through the match-lighting hole in the right hand side of the body of the barbecue until the lit end is alongside the right hand burner. Push and turn the right hand control knob anti-clockwise to the high position taking care to protect yourself from flames.
- When the burner is lit turn the remaining burners from right to left.
- Confirm that each burner is lit before turning on the next burner.
- **If the right hand burner fails to light, turn off the gas and contact your local Outback dealer or our customer services department on (01622) 671771 for assistance.**

## **MAINTENANCE**

- ▲ Never handle hot parts of the BBQ with unprotected hands.
- ▲ Never douse the BBQ with water when its surfaces are hot.

### **General**

- Regularly clean your BBQ between uses and especially after extended periods of storage.
- Do not leave the BBQ uncovered and exposed to the elements when not in use. Heavy duty covers are available as an accessory from your Outback® stockist. Even when your barbecue is covered for its protection, it must be inspected on a regular basis as damp or condensation can form which may result in damage to the barbecue. It may be necessary to dry the barbecue and the inside of the cover. Any rust that is found that does not come into contact with the food should be treated with a rust inhibitor and painted with barbecue paint or a heat resistant paint. Wooden parts may also need to be cleaned and treated. Chrome plated warming racks etc. should be coated with cooking oil.
- Lava rock can be cleaned by lighting the burners on full for 3 to 5 minutes. This should be done with the hood in the raised position. Heavily impregnated lava rock should be turned over so that the dirty side faces the burners in order to burn off any residue. We do not recommend washing lava rock.
- The wooden shelf, shelf insert and bottom slats are made from hardwood ideally suited to outside

conditions. Hardwood will naturally weather and change its appearance and it is quite natural for small cracks to appear on the surface of the wood. The wood should be regularly inspected and any weathered or damaged surfaces should be recoated promptly with Yacht varnish or an external grade Polyurethane varnish. Follow the varnish manufacturer's instructions for preparation and application.

- All screws and bolts should be checked and tightened if necessary on a regular basis.

### Burner Removal

To remove the burners (see photos):

1. Remove the burner clip.
2. Lift the burner upwards.
3. Gently pull the burner mouth away from the valve injector.
4. Lift the burner out.

Venturi tube

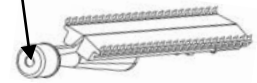

To re-install the burners (not depicted):

1. Slide the burner mouth over the valve injector. The injector should sit centrally within the burner venturi tube.
  2. Lower the burner into the body.
  3. Insert the locating stud through the support.
- Lock into place by inserting the burner clip through the stud.

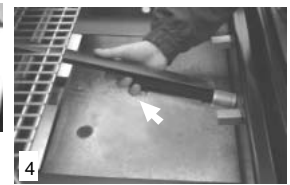
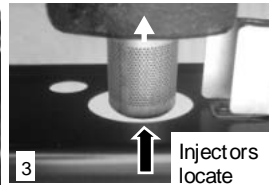

- Your burners have been preset for optimal flame performance. You will normally see a blue flame, possibly with a small yellow tip when the burner is alight. If the flame pattern is significantly yellow, this could be a problem caused by grease from cooking blocking the burner or spiders or other insects in the burner venturi. This can result in the flow of the gas and air mixture being restricted or blocked which may result in a fire behind the control panel causing serious damage to your barbecue. **If this happens, the gas should be immediately turned off at the bottle.**
- Burners should be inspected and cleaned on a regular basis in addition to the following conditions:
  1. Bringing the barbecue out of storage.
  2. One or more of the burners do not ignite.
  3. The burner flame pattern is significantly yellow.
  4. The gas ignites behind the control panel.
- To clean a burner, remove it from the barbecue. It is quite normal for a cast iron burner to rust. The outside of the burner can be cleaned with a wire brush.
- Clean the portholes with a pipe cleaner or piece of wire. Take care not to enlarge the portholes.
- Clean the insect screen on the end of the venturi tube with a bristle brush (i.e. an old toothbrush).
- Clean the venturi tube with a pipe cleaner or piece of wire. You may need a torch to see into the venturi tube to make sure it is clear. You will see a pin inside the tube which is part of the burner assembly.
- Turn the burner up on end and lightly tap against a piece of wood to dislodge any debris from inside.

## Cleaning

<i>Material</i>	<i>Where used</i>	<i>Cleaning Method Recommended</i>
Stainless Steel	Centre hood panel	Clean using hot soapy water or with the use of a suitable cleaning product following the manufacturers instructions.
Porcelain enamel	Grills Griddles Hood	Enamel is a thin, glass based coating fused onto metal and as such needs to be treated with care. Cooking oil, together with fat from food being cooked can turn to carbon as a result of heating and result in black flakes coming away from the cooking surfaces. These are not harmful. Porcelain should be cleaned using hot soapy water or with the use of a suitable cleaning product following the Manufacturers instructions. Due to the weight of the grills and griddle, we do not recommend cleaning in a dishwasher.
Chromium plated	Warming rack	Wash with hot soapy water. A chrome cleaner may be used if required. To prevent rusting, wipe with cooking oil after rinsing and drying.
Wood	Shelves and shelf inserts	Wipe with a cloth wrung out in hot soapy water and dry.
Plastic Paint	Trolley excluding wooden shelving Body Utensil trays	Wipe with a cloth wrung out in hot soapy water and dry. Excess fat and food debris can be removed from inside the body using a plastic or wooden scraper. Do not use abrasives. If rust appears on the body it should be treated with a suitable rust inhibitor and painted with a heat resistant paint.
Galvanised	Drip tray Foil Liner	Excess fat and food debris must be removed using a plastic or wooden scraper. This needs to be carried out between each use of the BBQ. Excessive build up is likely to lead to a fat fire which can be hazardous and damage the BBQ. <b>This is not a fault in the BBQ and therefore is not covered by the terms of the warranty.</b>  If required, the tray and oil liner can be washed in hot soapy water.
Cast Iron	Burners	Any food debris should be removed on a regular basis. For detailed burner instructions refer to MAINTENANCE on Page 22 and 23.

## **Troubleshooting**

<b><i>Problem</i></b>	<b><i>Possible Cause</i></b>	<b><i>Solution</i></b>
<b>Burners will not light using the ignition system</b>	LP gas bottle is empty	Replace with full gas bottle
	Faulty regulator	Have regulator checked or replace
	Obstructions in burners	Clean burners
	Obstructions in gas jets or gas hose	Clean jets and gas hose
	Electrode wire is loose or disconnected on electrode or ignition unit	Reconnect wire
	Electrode or wire is damaged	Change electrode and wire
	Faulty integral igniter	Replace gas valve complete with integral igniter
	Incorrect electrode gap/ Bent collector box	The gas collector box around the electrode needs to be in line with the burner with a gap of 3 to 4mm between the end of the electrode and the tag on the end of the collector box. Realign the collector box as required.
<b>Burner will not light with a match</b>	LP gas bottle is empty	Replace with full gas bottle
	Faulty regulator	Have regulator checked or replace
	Obstructions in burners	Clean burners
	Obstructions in gas jets or gas hose	Clean jets and gas hose
<b>Low flame or flashback (fire in burner tube - a hissing or roaring noise may be heard)</b>	LP gas bottle too small	Use larger gas bottle
	Obstructions in burners	Clean burners
	Obstructions in gas jets or gas hose	Clean jets and gas hose
	Windy conditions	Use BBQ in a more sheltered position
<b>Gas valve knob difficult to turn</b>	Integral ignition system jammed Gas valve jammed	Replace gas valve complete with integral igniter

## Technical Specifications

Model Name	CE Approval	Heat Input	Burners	Injector Size	Gas / Pressure
Outback® Diamond 3 Burner	0359 359BR128	11.8kW	3	1.04	Butane/ 28-30mbar
Outback® Diamond 6 Burner	0359 359BR128	15.75kW	6	0.81	Propane/ 37mbar
Countries of Use: <small>I<sub>3+</sub>(28-30/37)</small> BE, CY, CZ, EE, FR, GR, IE, IS, IT, LV, LT, LU, PT, SK, ES, CH, GB <small>I<sub>3B/P</sub>(30)</small> CY, CZ, DK, EE, FI, GR, LV, LT, LU, MT, NL, NO, SK, SI, SE, TR <small>I<sub>3B/P</sub>(50)</small> AT, DE, HU, SK, CH <small>I<sub>3B/P</sub>(36)</small> PL					

For reference and correspondence, record your serial number here.  
(See sticker on side of barbecue body.)

**Serial No.** \_\_\_\_\_

This number may be required when ordering spare parts or accessories. A part reference number may also be required where applicable.

**In the unlikely event that you experience problems with this barbecue, please contact:**

Customer Service  
 Outback UK  
 Unit 2 Farleigh Hill  
 Tovil  
 Maidstone  
 Kent  
 ME15 6RG  
 Tel: 01622 671771  
 Fax: 01622 673101  
 e-mail: [customerservice@outbackuk.com](mailto:customerservice@outbackuk.com)